

hup! Base Installation Guide

Version 1 | 01.25

hup! - A Building Revolution from Ultraframe

hup![®]
The better way to build

Introduction

Thank you for choosing hup!. This guide is designed to make building as straightforward as possible. Before you commence the hup! build, please take a moment to read the guide. This guide is written on the basis that a qualified surveyor has undertaken correct checks for the capability / structural performance of any existing framework / walls / foundations to verify they are fit for purpose. Any feedback - positive or negative - is welcomed so we can make our systems even better.

Contents

Health and Safety	3	Preparing the site: ground screw	9-10
What's in the box?	3	Base Assembly: ground screw	11-13
Setting the base out	4	Fitting skirt panels	14-15
Preparing the site: pads	5	Flooring	16
Base assembly: pads	6-8	hup! walls	17

For technical support, please contact us on **01432 801805** or email hupbase@ultraframe.co.uk.

For everything you need to know about hup!, including guides and explainer videos, visit www.trade-hup.co.uk

Building Regulations

The hup! Base has been assessed and pre-approved by Stroma (national building inspector) to make Building Regulations easy.



Health and Safety

Site safety is paramount. The Construction (Design & Management) Regulations 2015 apply to the whole construction process, on all construction projects from concept through to completion. Compliance is required to ensure construction projects are carried out in a way that secures health and safety. The installation company shall be responsible for the safety of all of the fitting team, the customer and members of the public.

The Surveyor should have carried out a risk assessment to reduce risk on site and this should have been discussed with you prior to starting.

Always use equipment in line with manufacturers recommendations. Personal Protective Equipment - such as goggles, gloves, mask and ear defenders – should be used when appropriate.

Careful consideration should be given to the safe disposal of all packaging - packaging is predominantly made from recycled materials and can be readily recycled.

What's in the box?

Fixings Supplied



Fixing down plate
Base to pad



10 x 50 Sleeve anchor
Fixing down leg to pad



Jacking leg & plate
Levelling the base



10 x 110 Hex anchor
Base back cill to house



10 x 110 Hex nut & bolt
Splitter beam



M6 x 60 nut & bolt
Joist to hanger



50mm self tapping screw
Skirt to base & standard flooring to joist.

Enough DPC for the Base and Walls will be provided. Weed suppressing membrane is also included. Additional 300ml DPC will be needed for the hup! walls. If you are using brick slips on the skirt then glue, mortar and your chosen brick slips are also provided.



Damp Proof Course (DPC)



Weed suppressing membrane



Brick slips



Glue for brick slips



Mortar for brick slips

Setting the base out

This section explains the necessity to ensure that your base is assembled in the correct position from the host wall. Any discrepancies should be noted and measures taken to adjust as necessary.

Setting Out Point (SP)

As the conservatory/extension will need to be built at 90° to the ground it is important to check the angle of the wall/s you are building against.

If the wall/s leans outwards, a plumb line should be fixed to the highest point where the roof will touch the wall. Where the plumb line meets the ground is where the base should be set out from (SP). The gap will need to be filled with packers (not supplied). The base and wall size will need to be started from this point.

If the wall leans backwards the base should be started against the wall (SP). The gap in this situation is at the top therefore packers (not supplied) will be needed to ensure the wall is fixed in the correct position and level.

Note Any additional trims to cover large gaps are not included with the base or conservatory/extension and should be purchased separately. If house is leaning outwards, you may need to specify extra skirting when you order.

House wall leaning outwards

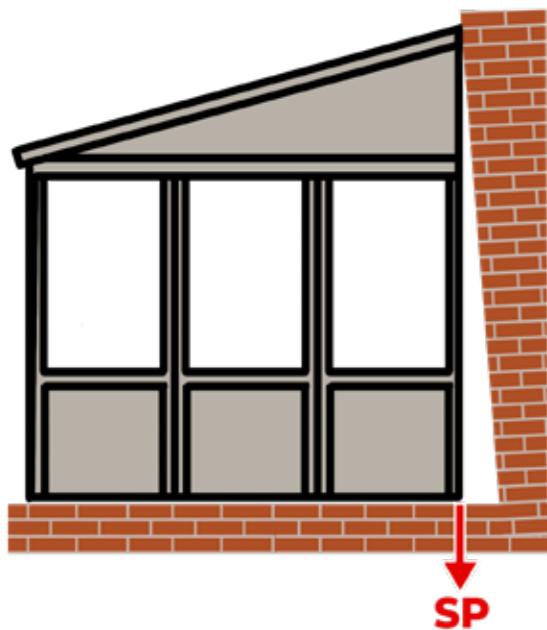

House wall leaning inwards

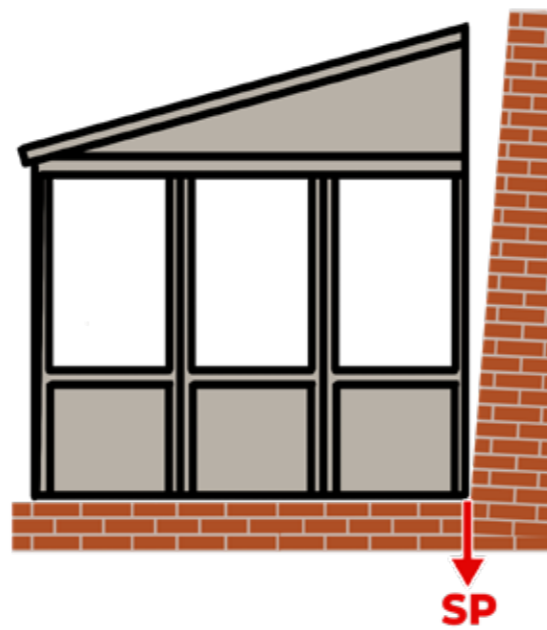

If using ground screws and the screw foot, refer to page *** onwards.

Preparing the site: pads

If you are using pads which are required under each fixing down leg. Refer to the pad plan provided for the location and number of concrete pads required. The back cill does not require concrete pads because this is fixed to the house wall. Any legs fitted to the back cill are used for levelling and need to rest on something firm e.g. paving slabs or blocks.

For each pad dig out a hole, 450mm square x 450mm deep (the 450mm is a minimum depth: to comply with Building Regulations this depth will need to be verified by Building Control).

it may be necessary to check the required depth with local building regulations).

The pads should be dug down into firm natural ground, but other factors should be taken into account such as:

- The type of subsoil
- Presence of trees/roots
- Location and invert of drains
- On clay, sand or peaty subsoil further excavation will be required.

Fill the holes with concrete (C40 grade recommended) to the level specified on the pad plan. This measurement is from the top of the pad to the steel (DPC) level.

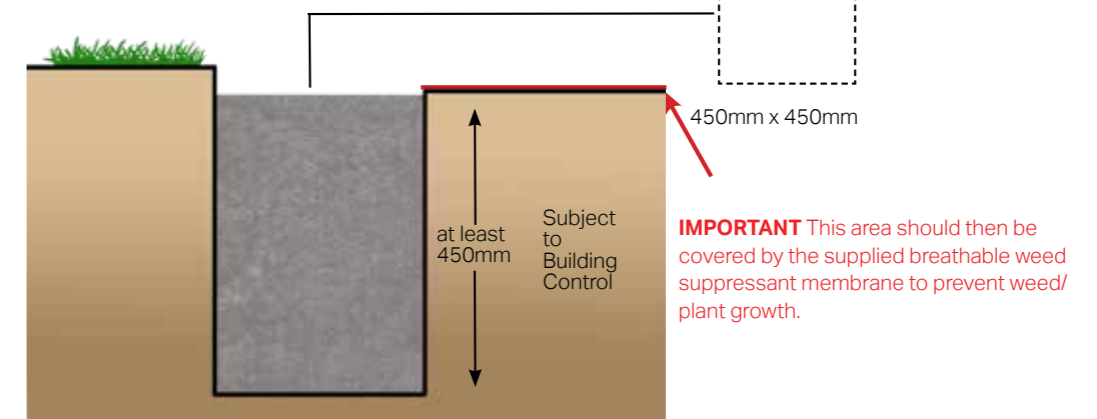

Note Concrete pads should be below ground level based on the survey measurements given. However if a pad is considerably higher than ground level, please contact hup! Base tech support 01432 801805.

hup! Base ground excavation required

It is imperative to dig out beneath the base to provide adequate airflow. On hup! Bases this is 150mm down from the top of the back cill or 70mm from below the back cill.

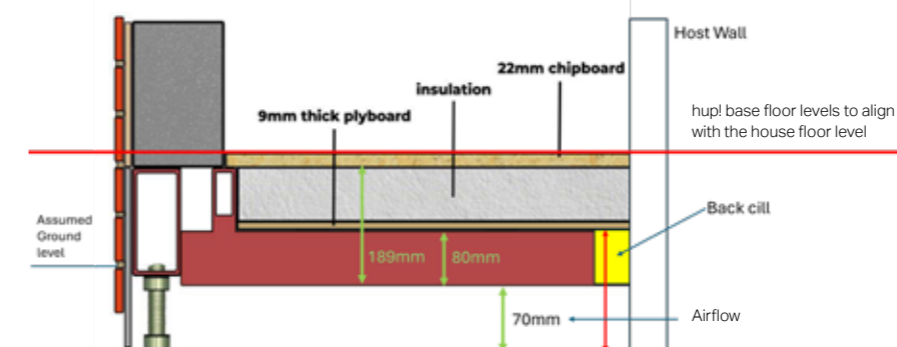

Example
+39mm to allow the base to be sited
+70mm for air flow
109mm removal/excavation required to the entire footprint of the base of any top soil or vegetation.

Please note +75mm around ground screws so you can access the bolts so to secure in place.

Base assembly: pads

1.0 Screw lock nuts onto all jacking legs. Screw jacking legs into the nuts welded onto the underside of the back cill section. Position the load-bearing plates (70mm circular washers) under all jacking legs. These jacking legs should be placed on something firm to prevent sinking e.g. paving slabs or blocks.

1.1 Position the 80x80 back cill section against the house wall in the required position, allowing for 131mm insulation from the top of the chipboard to the top of the back cill.

IMPORTANT When matching your extension floor level to the existing house floor level you will also need to add the thickness of your floor finish to these measurements

The back cill section (against the house wall) will be shorter than the overall base size to allow for the side cills. The back cill section is set down lower than the side cills to allow for the ply and underfloor insulation.

If the chipboard floor panels land lower than the house DPC it will be necessary to insert a vertical damp-proof barrier between the floor insulation and the house wall. Ensure that the host wall is of sound construction and suitable to be fix to.

1.2 Ensure the back cill is level then pilot drill through the fixing holes using a 70mm masonry drill bit.

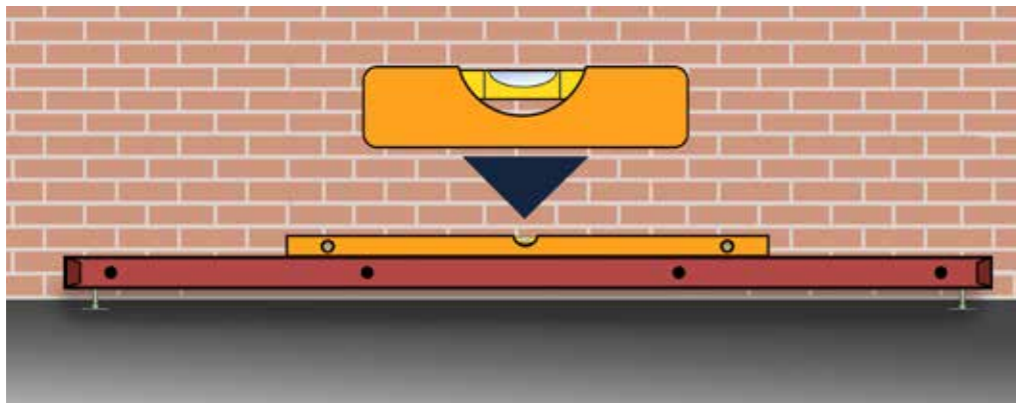

1.3 Remove the back cill section and re-drill pilot holes to a depth of 70mm using a 16mm masonry drill bit. Using the 10 x 110 hex anchors, insert the anchor sleeve into the holes and remove the bolts. Replace the back cill section, insert bolts and tighten using a 17mm socket.

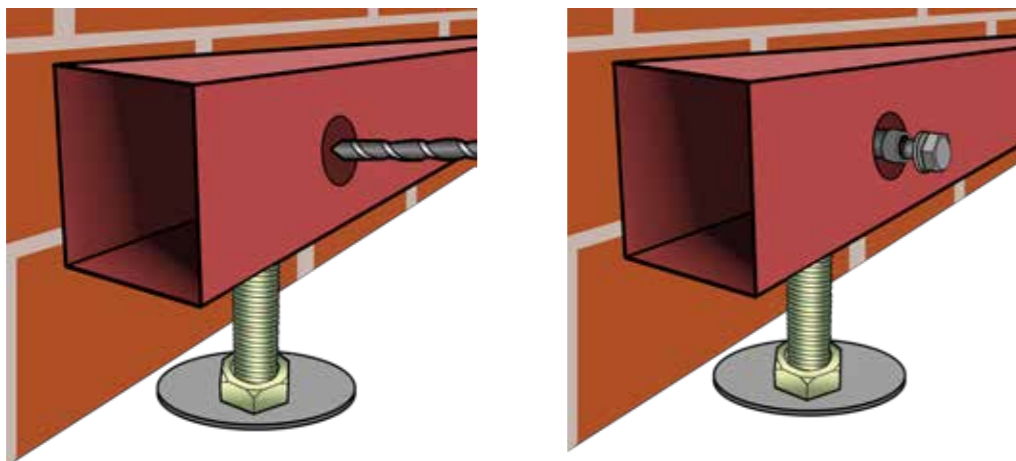

Base assembly: pads

1.4 Assemble fixing down legs, including lock nuts, and screw into the nuts welded onto the underside of the side cills where there is a pad.

NOTE A fixing down leg is required on each pad to secure the base. In certain positions, there will be a second slot where a jacking leg will also be required to assist with levelling the base.

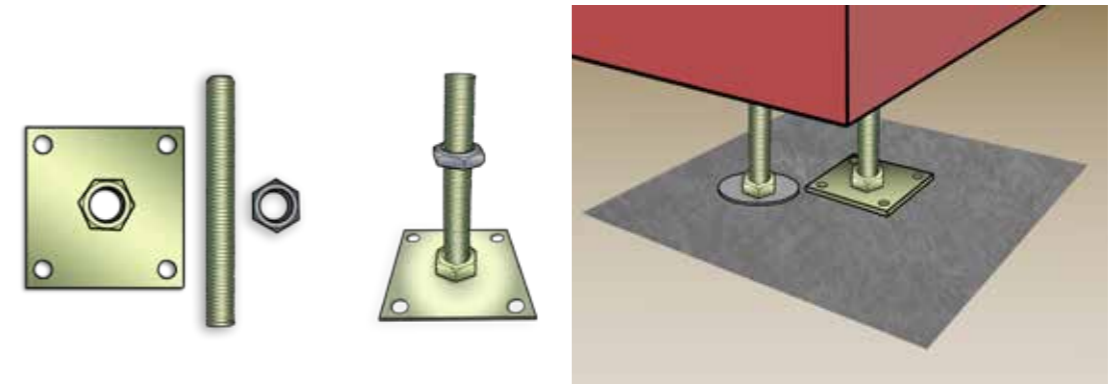

1.5 Fit the side cills to the back cill section by locating them onto the pre-welded studs with the corner fixing bracket. Fix with nut supplied but do not fully tighten at this stage.



1.6 Screw the jacking legs and fixing down legs into the nuts welded onto the underside of the front cill section.

1.7 Working your way around, adjust the fixing down legs to the required height and level using a spirit level. Check that the base is square and tighten all joints. Re-check levels and tighten lock nuts on the fixing down legs.

Your base should now be square and level

Base assembly: pads

1.8 Slot the floor joists into the 'u' support brackets, and secure using M6 x 60 bolts and nuts supplied. Tighten with 10mm spanner. The joist supports, if supplied, should be fitted centre of the joist length and the jacking legs should be adjusted and locked at this stage.

NOTE Not all hup! Bases are supplied with joist supports. Similar to jacking legs, joist supports should be placed on something firm to avoid sinking e.g. paving slabs or blocks.

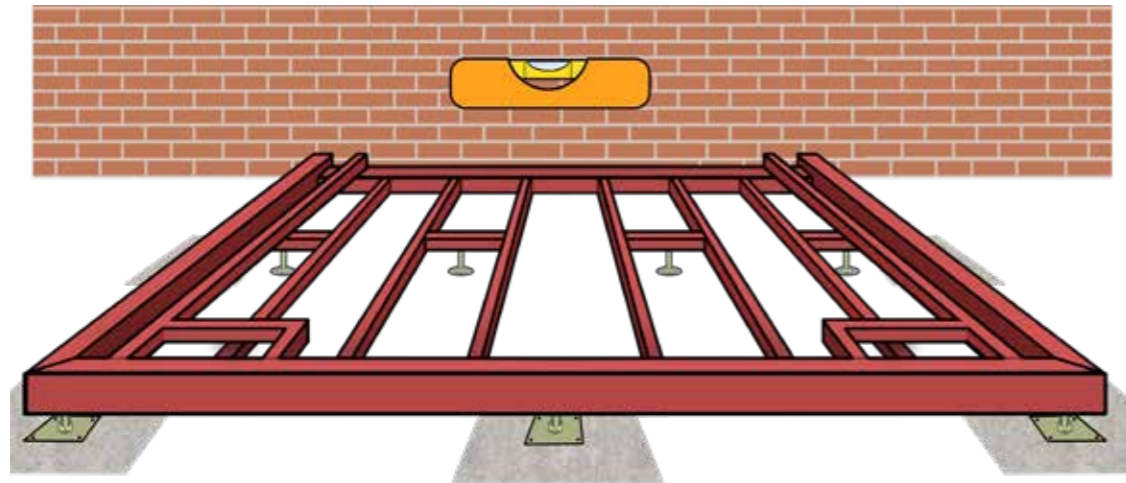

1.9 Fix leg assembly down to concrete pad using 10 x 50mm sleeve anchors supplied. Pre-drill concrete using a 10mm masonry bit. Only one fixing is required per leg.

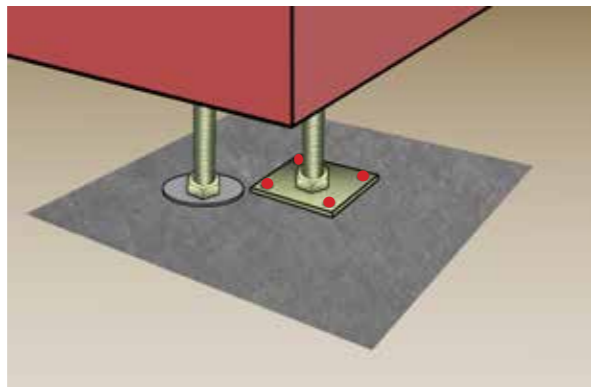

Preparing the site: ground screw

A hup! Base can also be fitted on ground screws using The Screw Foot. As you would with pads, refer to the screw plan for screw depths and positions. The depth is calculated from the base's DPC to the top of the screw plate.

The screws also require a 400mm x 400mm x 75mm deep hole dug beneath the top plate of the screw to allow access for bolt tightening.

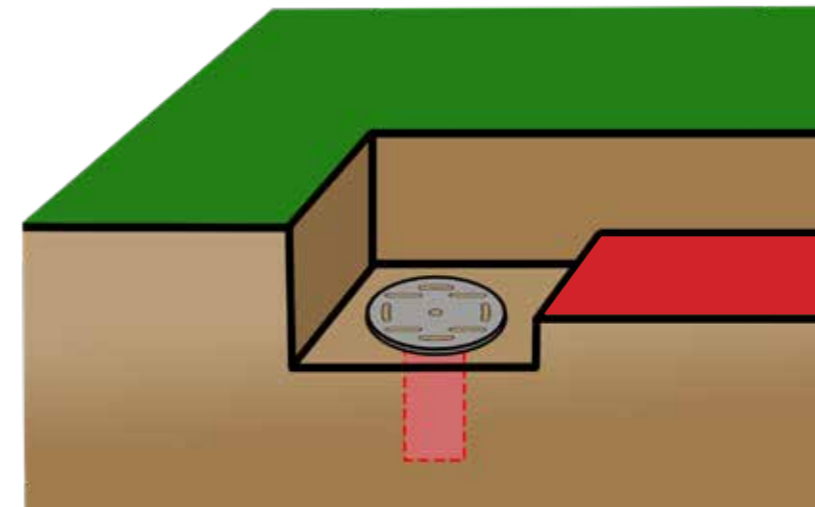

IMPORTANT This area should then be covered by the supplied breathable weed suppressant membrane to prevent weed/plant growth.

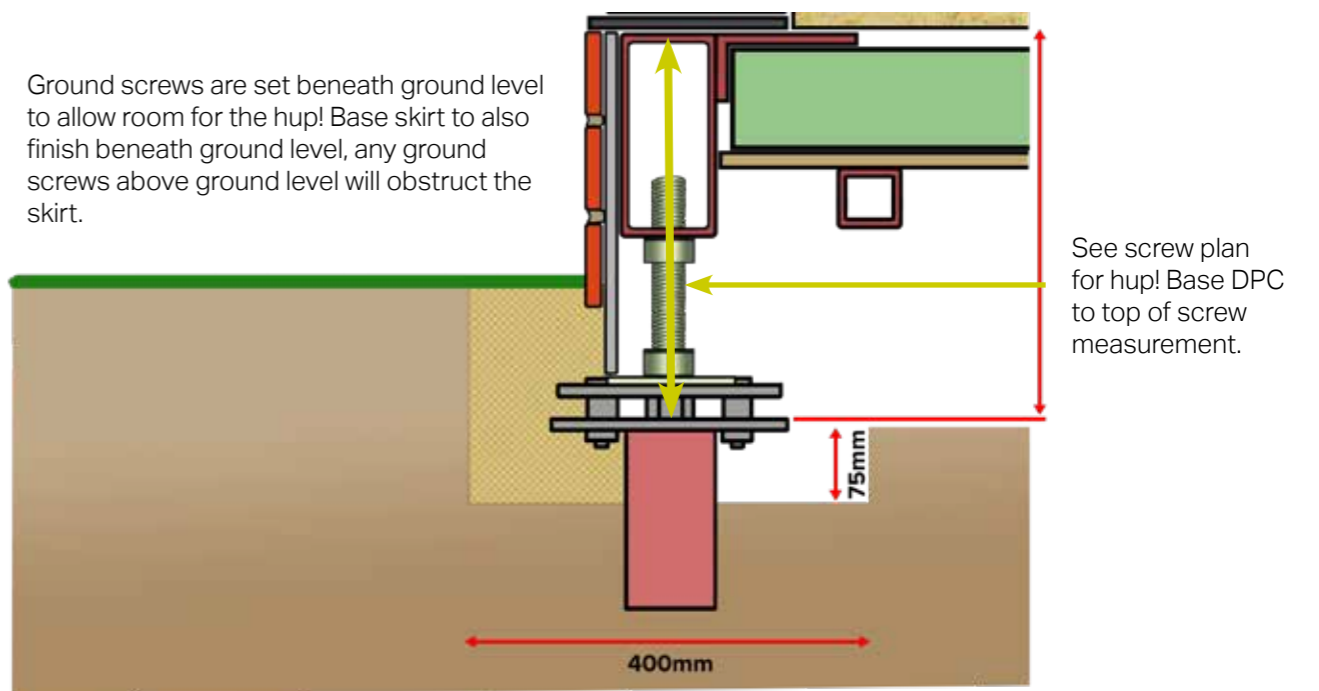

Preparing the site: ground screw

Ground screws need to be fixed accurately to the positions shown on the screw plan. The Screw Foot has a side to side tolerance of 50mm.

Any ground screw over 50mm away from the position labelled on the screw plan needs to be corrected by the ground screw company. It is not suitable to have the jacking leg more than 50mm away from the centre of the ground screw top.

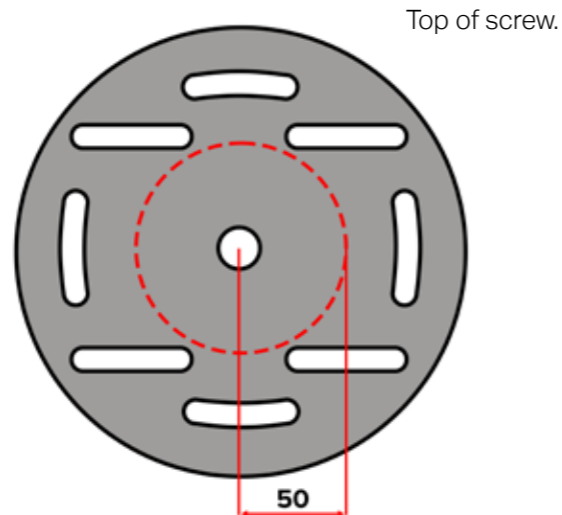

IMPORTANT It is imperative to dig out beneath the base to provide adequate airflow. On hup! Bases this is 150mm down from the top of the back cill, this area is then covered by the weed suppressant membrane supplied.

It is the responsibility of the ground screw supplier to demonstrate that the applied vertical and horizontal forces can be resisted by the installed ground screws. An assessment of the vertical load, wind pressures and subsequent lateral forces applied to the ground screws must be undertaken by the ground screw supplier or building provider on a project-by-project basis in accordance with the relevant wind loading codes of practice and the geometry of the proposed building.

Test certificates that state the passing of the required standard for Building Control must also be supplied.

Base Assembly: ground screw

2.0 Screw lock nuts onto all jacking legs. Screw jacking legs into the nuts welded onto the underside of the back cill section. Position the load-bearing plates (70mm circular washers) under all jacking legs. These jacking legs should be placed on something firm to prevent sinking e.g. paving slabs or blocks.

2.1 Position the 80x80 back cill section against the house wall in the required position, the setting out height of this section depends on the thickness of the underfloor insulation being used.

IMPORTANT When matching your extension floor level to the existing house floor level you will also need to add the thickness of your floor finish to these measurements.

The back cill section (against the house wall) will be shorter than the overall base size because of the way the hup! Base is constructed. The back cill section is set down lower than the side cills to allow for the ply and underfloor insulation.

If the chipboard floor panels land lower than the property's DPC it will be necessary to insert a vertical damp-proof barrier.

2.2 Ensure the back cill is level then pilot drill through the fixing holes using a 10mm masonry drill bit.

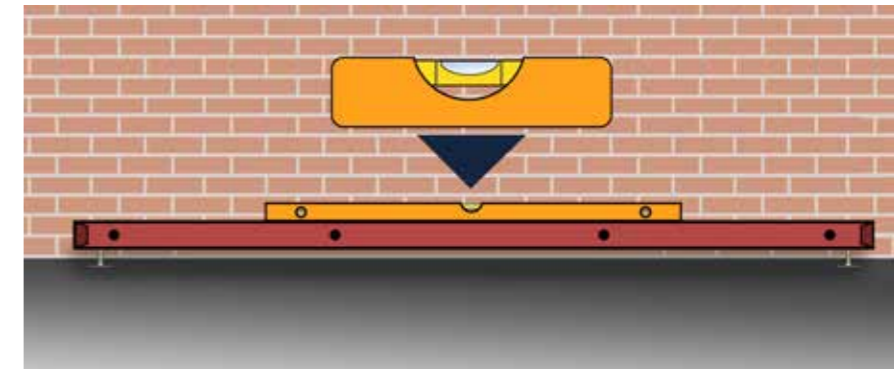

2.3 Remove the back cill section and re-drill pilot holes to a depth of 70mm using a 16mm masonry drill bit. Using the 10 x 110 hex anchors, insert the anchor sleeve into the holes and remove the bolts. Replace the back cill section, insert bolts and tighten using a 17mm socket.

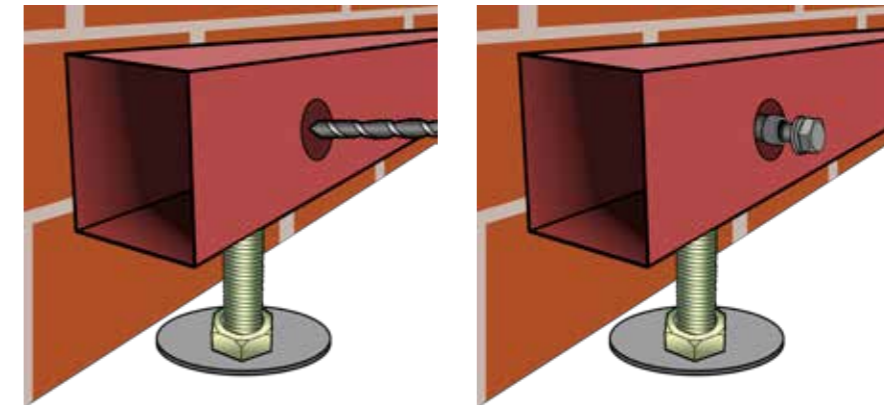

Base Assembly: ground screw

2.4 Using the preassembled Screw Foot and leg and ensuring the locking nut is fitted, screw the leg into the nuts welded onto the underside of the side cills.

NOTE The middle nut is welded onto the leg to assist with height adjustment. You should also have a locking nut above this to lock off the leg to base.



IMPORTANT While the base isn't finally fixed, be aware that there is a risk of the base moving and dropping off the ground screws. We strongly recommend getting a temporary fixing through the leg and ground screw at this point.

2.5 Fit the side cills to the back cill section by locating them onto the pre-welded studs with the corner fixing bracket. Fix with nut supplied but do not fully tighten at this stage.



2.6 Screw the Screw Foot and leg into the nuts welded onto the underside of the front cill section.

2.7 Making sure the bottom locking nut is lifted and the large 70mm washer is loose, ensure the 24mm Jacking leg (threaded bar) is taking the weight of the base, working your way around, adjust the Screw Foot and legs to the required height using the welded locking nut and level using a spirit level.

NOTE No leg should be more than 50mm away from the centre of the ground screw. If this occurs the ground screw will need to be moved.

Your base should now be square and level!

Base Assembly: ground screw

2.8 Now the base is sitting on the ground screws and level, locate the foot plate to make sure 4 bolts can be used to fix it down. Turning the plate and adjusting the position of the slot will help find the best location. Fixings need to go through 4 of the 8 highlighted slots. The plate will always be situated centrally above the ground screw and all 4 spacers will be in contact with the top of the ground screw

NOTE For ground screws that are on a slight angle, use the packing shims supplied to ensure all points of the plate are in contact with the ground screw. The weight of the base still needs to be transferred through to the ground screw via the leg.

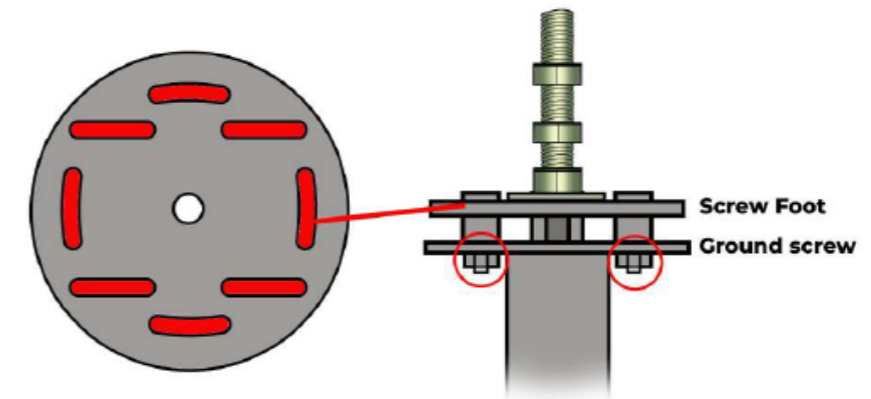

2.9 Fix the Screw Foot down to the ground screw using 4 x 60mm coach bolts supplied. Tighten using the nuts making sure the washer has been used between the nut and the underside of the ground screw. Lock into position using the lower locking nut to secure the entire leg.

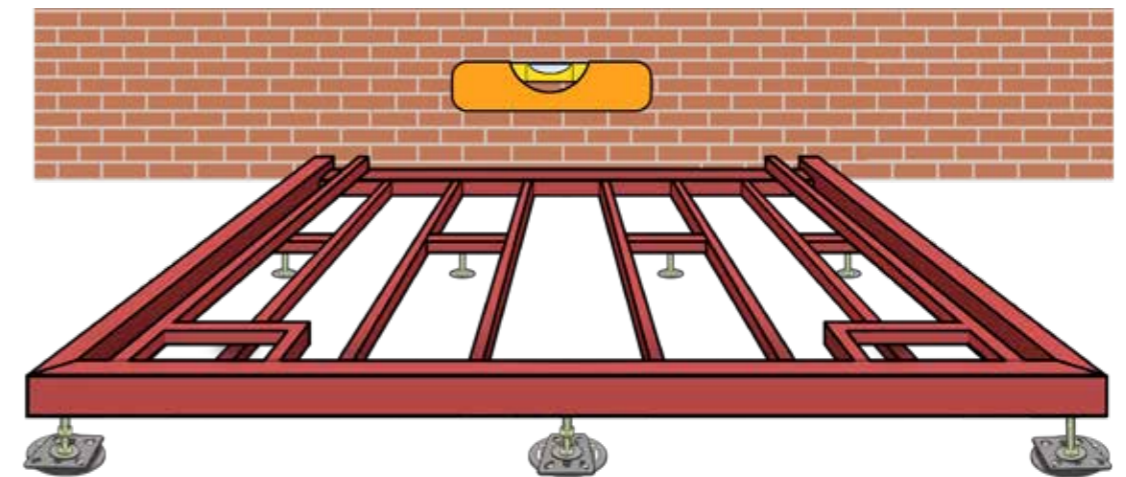

Fitting skirt panels

3.0 Lay out the skirt sections in the order they are to be fitted. The panels are lettered to correspond with the skirt plan and ensure the brick slips are flush with the top edge. Fit the panels so the top edge lines up with the top edge of the steel base.

NOTE The ends of the panels that correspond with an external corner of the base frame must line up with the edge of the steel base frame. Do not overlap panels on the corners.

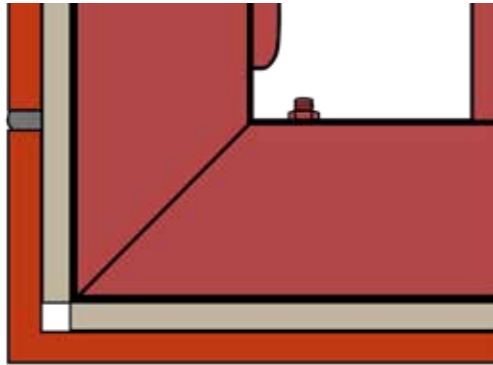

3.1 Using the 50mm self tapping screws supplied, fix where the brick slips are still to be fitted and through perpendicular mortar joints if extra fixing is required.

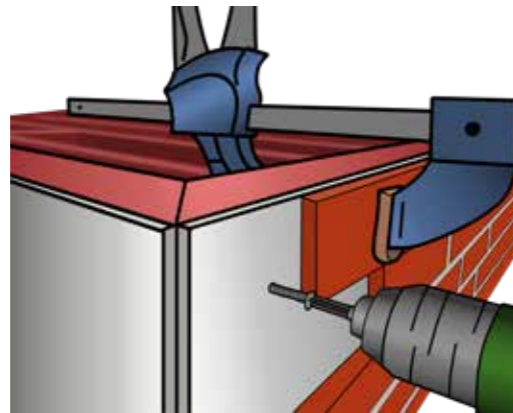

3.2 Once fully constructed, use the adhesive supplied to fix the spare brick slips in place. You will need to use some 10mm spacers to position the brick slips on the skirt panels. Press the bricks firmly into place.

NOTE Be aware of the weather forecast during the building process, the construction adhesive supplied can be used in temperatures between 5°C and 35°C.

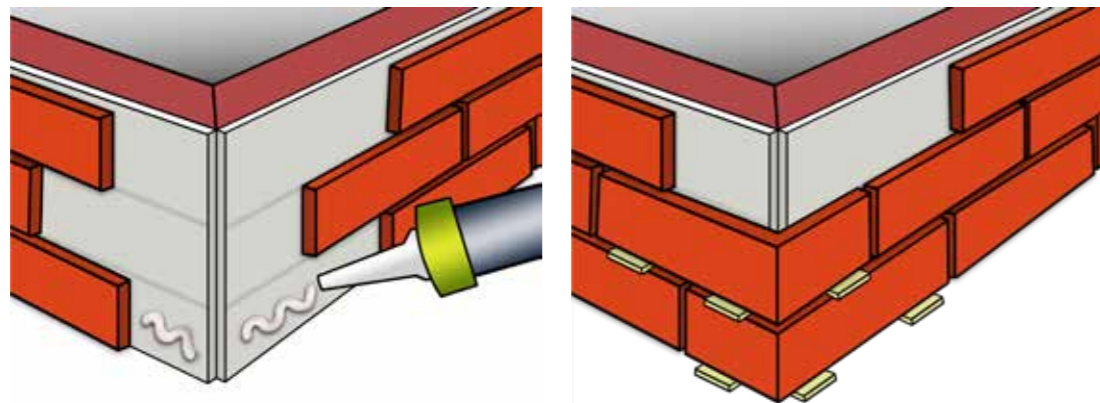

Fitting skirt panels

Mortaring the skirt

3.3 Once fully constructed, seal the joints in the brick backer panels with the construction adhesive supplied. Use the same adhesive to stick the spare brick tiles in place. **NOTE** You will need to use some 10mm spacers to position the brick slips on the skirt panels. Press bricks firmly into place.

3.4 To point the joints, mix the mortar supplied with water until a consistency of a stiff cream is achieved. Fill the joints around the bricks completely using a pointing bag. Ensure you follow the instructions on the mortar supplied. **NOTE** Check correct consistency by filling the bag, the mortar should hang from the end of the nozzle when the bag is shaken down.

3.5 Allow the mortar to dry until fairly firm. We would recommend that the mortar is firm enough that when pushed in with a finger only a small indentation is left behind. It should have a dull finish, be moist but not wet and somewhat gritty. Use a curved pointing tool to strike off mortar and then, when almost dry, remove any remaining mortar with a soft brush.

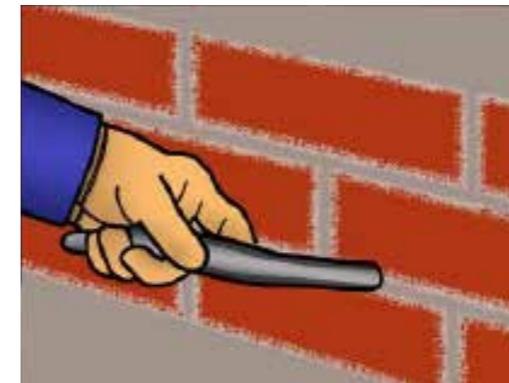

NOTE Do not be tempted to strike off when the mortar is too moist. Overworking the mortar may create colour changes. Every time you work it, the moisture is drawn out and could result in a lighter-coloured mortar when dry.

hup! Bases with a 225mm skirt come with an un-bricked 35mm cement board bottom to allow for backfilling from the outside. This additional 35mm enables us to have the air gap under the base that is required for Building Regulations.

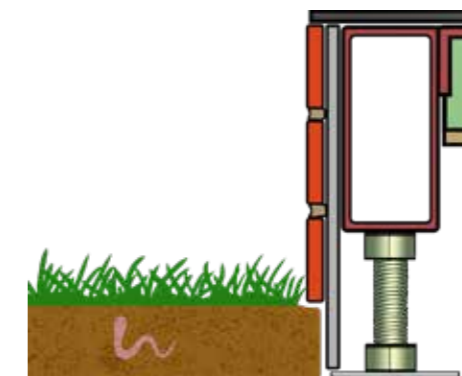

Ready to Render and Plain Skirts

Fix in the same way as brick skirts using the 50mm screws provided. You will need to cut the boards to length before fitting. It is recommended that air vents be fitted in the side skirt panels and a render board used between hup! calcium silicate board. **NOTE** The vent location is cut into the steel so vent cut outs in the skirt must match the steel's vent locations. Vents are cut oversize in the steel, cut skirts to air brick size.

Flooring

NOTE This is a floating floor, so if finishing with a floor tile or similar, we recommend seeking advice. If extra fixings are required, long self-drilling screws are available (price on request).

Tip: It is advised to make a note of the joist centres so that lines can be drawn on the flooring to guarantee the correct fixing down positions into the steel joists.

3.6 Deck out the floor area with 9mm thick plyboard, fixing down with the 50mm self-drilling screws supplied.

3.7 Cut the 100mm PIR to size filling the same area with the underfloor insulation. The top of the insulation will finish flush with the top of the outer steel frame.

3.8 Start laying the 22mm chipboard flooring directly onto the insulation from the rear left-hand side of the base, looking towards the house. Lay the sheets the correct way up as marked. Use the off-cut from the last run to start the next. It is advisable to glue the joints of the chipboard and to glue the chipboard to the insulation below. Waterproof glue should be used, but is not provided.

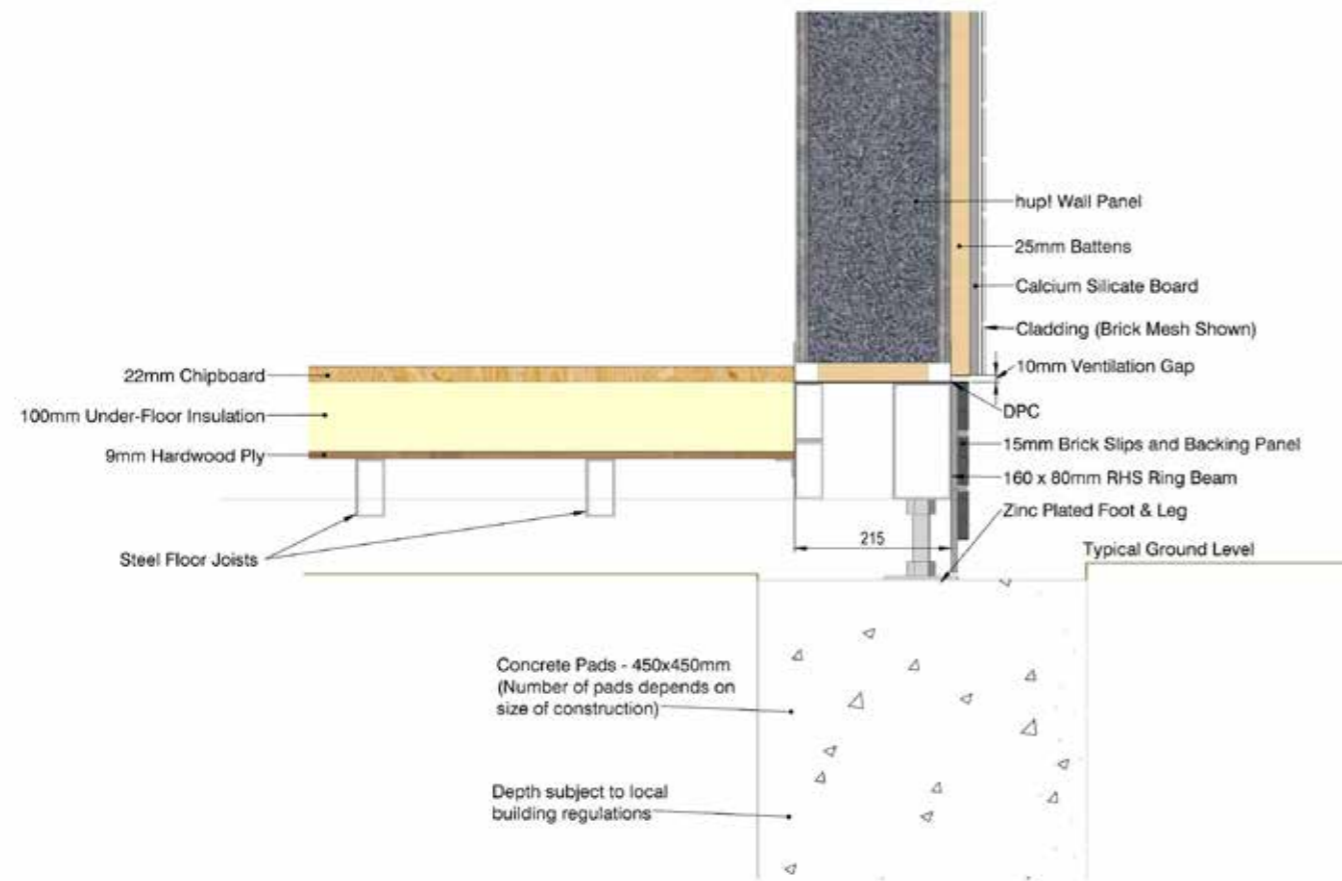

NOTE It is recommended to allow a 10mm expansion gap around the outside edges of the flooring. The floor is now ready for finishing with your choice of covering.

hup! walling

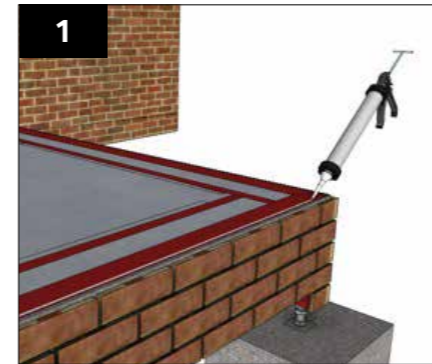

Apply silicone to the outer and inner edge beams of the steel base work.



Lay down the DPC on the outer edge and inner edge beams of the steel base work. Then apply a silicone bead to the outer edge of the DPC to seal to the outer steel angle on the hup! Base tray.



Install the hup! Base trays in accordance with the hup! installation guide.



Install the hup! walls in accordance with the hup! installation guide ensuring the vertical DPC is in place at the host wall.



Finish your hup! walls.

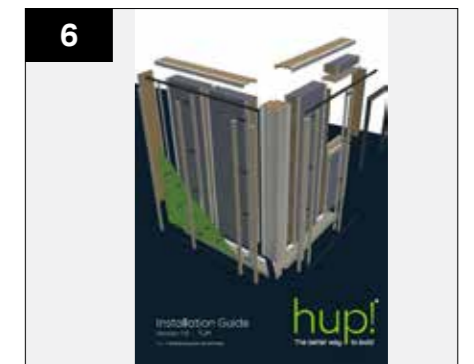

Refer to the hup! install guide for the rest of the build.

hup! Base Installation Guide

Version 1 | 01.25

JN: 9280 | PC: ***

hup! - A Building Revolution from Ultraframe

hup![®]
The better way to build