

Flatroof

By Ultraframe



Flat Roof | Specification Guide

An integrated solution with lanterns and flat skylights



Contact

Customer Service
01200 452 916
csi@ultraframe.co.uk

Marketing Support
01200 452 367
marketing@ultraframe.co.uk

Quotations
01200 452 901
flatroofsales@ultraframe.co.uk

Technical Support
01200 452 918
techsupport@ultraframe.co.uk

Contents

Summary of specification steps

This guide is designed to give step by step guidance to specify the Flat Roof resulting in completion of a simple order/quote form. The roof can be ordered using the form on pages 29 to 31.

Introduction **04**

Section 1

Max base sizes / Calculating your roof area **06**

Roof configurations **07**

Aperture locations **08**

Section 2

Lantern **10**

Flat Skylight **12**

Section 3

Soffit options on brick and frame / Soffit dimensions **14**

Fascia and Soffit Choices **15 / 16**

Outlets **17**

External lighting / Internal lighting **18**

Section 4.

Flat Roof as a conservatory replacement roof **19 / 20**

Elevation detail & structural posts **21 / 23**

Structural posts **24**

How to calculate your roof height **26**

Section 5.

Surveyors checklist **27 / 28**

Order / Quote form **29 / 31**

Welcome to the Flat Roof specification guide

The Flat Roof System is designed for use on conservatories, orangeries or extensions and is supplied as an integrated solution with lanterns or flat skylights. It is also light enough (only 51 kg/m²) to be used as a conservatory roof replacement providing the structure below is adequate (see page 20).

Using the latest Ultrapanel technology and pre-manufactured to the specifications, the Flat Roof will be quick to build, hassle-free and no cutting or drilling on site. Flat Roof has been designed to be installed by trained conservatory fitters and is fully compliant to the latest Building Regulations with a U-Value of 0.14 W/m² K.

The Flat Roof is available for use on brick walls and frames of any size.

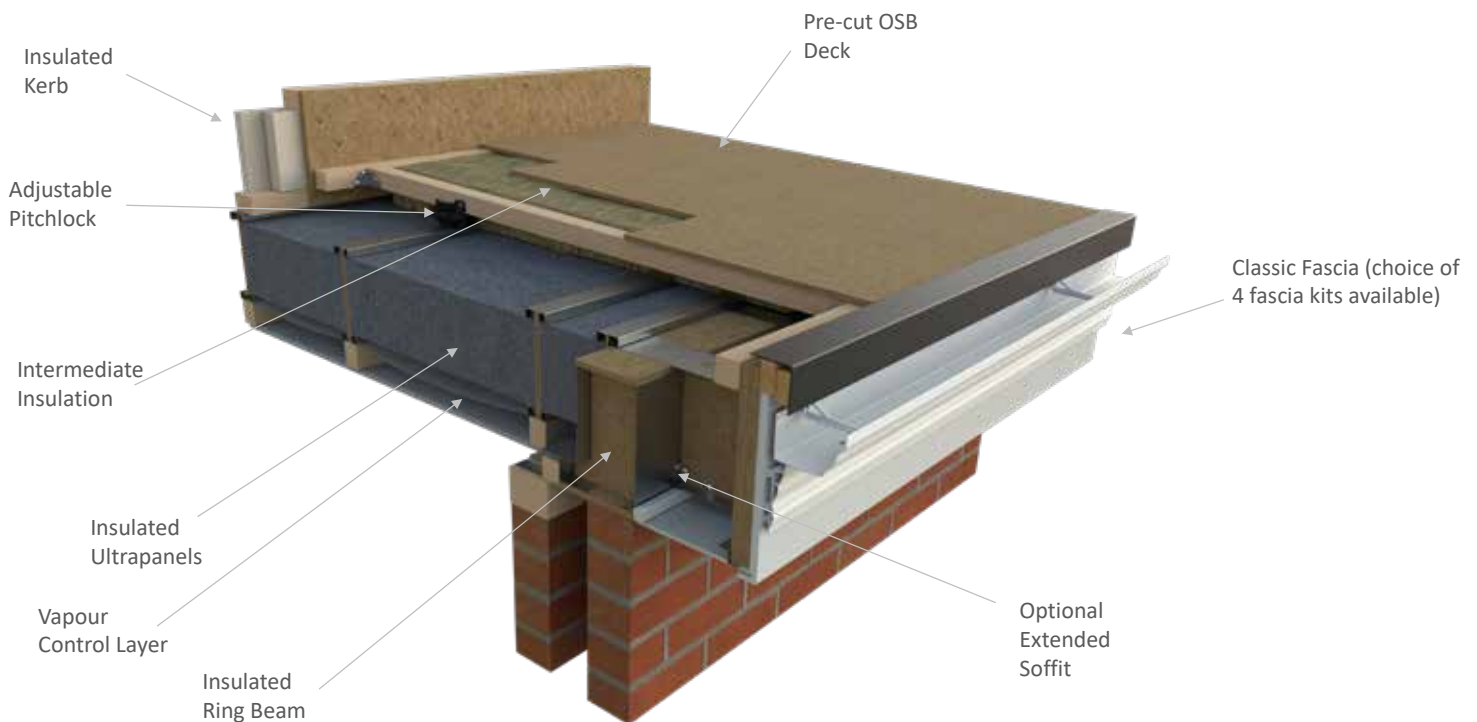

PLEASE USE THIS DOCUMENT FOR GUIDANCE ONLY. Always obtain a formal quotation for any specific project. A formal quotation from Ultraframe is the only accurate method of obtaining a price. Use the quote request order / quote form on pages 29 - 31.

Strongest The strongest Flat Roofing system



- Spans up to 5.6m unsupported without extra steels
- Ideal for large spans of bi-fold or sliding doors
- Can support roof lights up to 5.7m x 3m
- Engineered to postcode

Lightest The lightest Flat Roof system



- Weighs only 51kg/m²
- Designed to work with continuous window frames
- Uses Ultraframe's patented lightweight panel technology
- Panels are lightweight and easy to manoeuvre

Easiest One roof, one order



- Specify roof deck, kerb and roof lights in one order
- No need to wait for kerb sizes to order your roof lights
- Structural parameters of roof deck and roof lights - all taken care of

Customisable Unrivalled design flexibility



- Optional external soffit detail
- Choice of 4 fascia designs or create your own bespoke fascia
- Available in any RAL colour
- Compatible with any roof membrane
- Choice of 0, 1 or 2 apertures

Warmest Unrivalled thermal performance

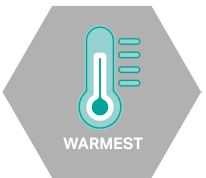

- U-Value as low as 0.14 W/m² K and fully Building Regulation compliant
- Generous 225mm of insulation
- Vapour control layer to eliminate risk of condensation
- Fully insulated ring beam
- Fully insulated, integrated kerb

Fastest Up to 50% faster



- Highest level of pre-fabrication of any Flat Roofing system
- No genie lift required
- Patented pending pitchlock fall system
- Easy-fit pre-manufactured soffit system

SECTION 1.

Max base sizes

- The maximum base size of 4000mm x 7000mm
- Roof can project up to 4m from host wall
- Rectangles & Squares only - 90° angles only

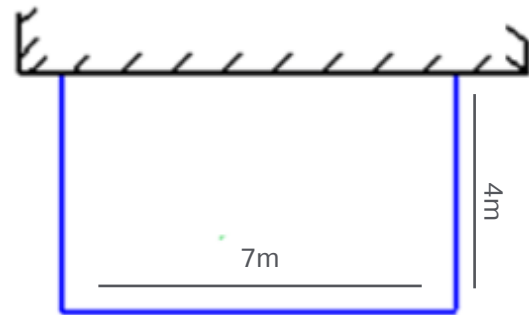

Calculating your roof area

The dimensions of the roof are taken from 'base size'.

This is the external face of the brick and if there are only windows on an elevation it is 30mm outside the external face of each frame, to allow for cills and bricks beneath floor level. Standard eaves height is 2400mm unless specified.

Datums

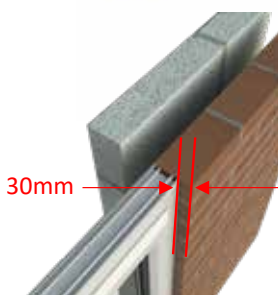
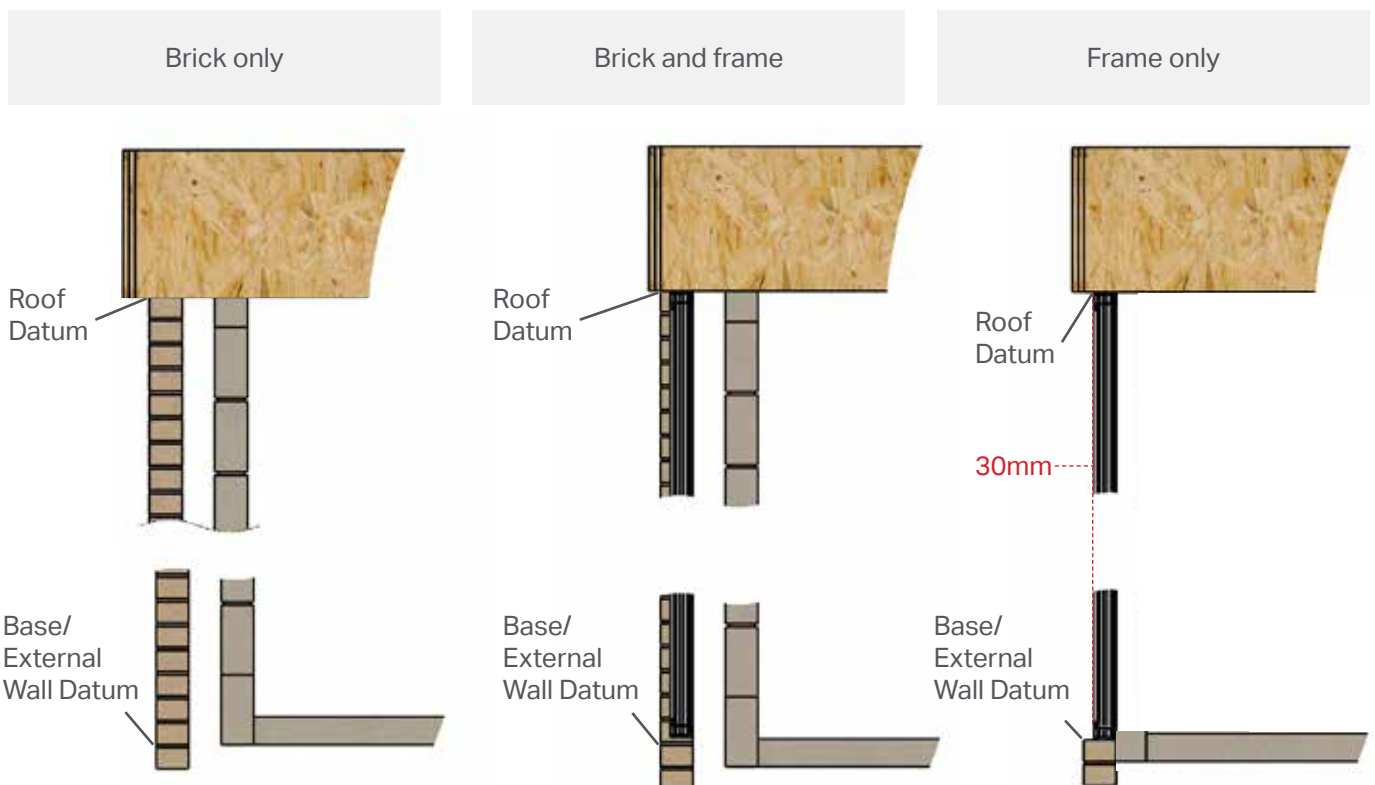

The roof can accommodate all wall thicknesses & frame thicknesses. For all dimensions in this document, the window is sat 30mm inside the external brick.

Roof configurations

The Flat Roof system is always rectangular or square and limited to the following configurations.

Small intrusions like soil pipes are available but chimney breasts are not. The host wall must be strong enough to support the roof, therefore, bungalows are not available. Maximum soil pipe size is 266mm.

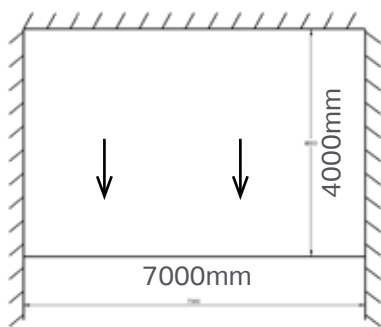

Fall to front elevation only

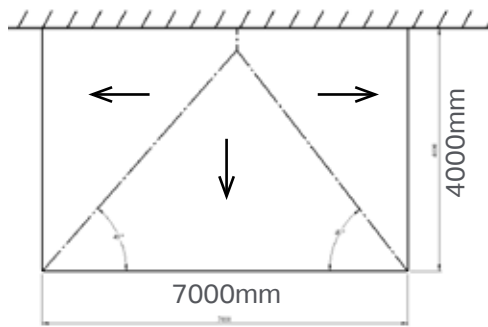

Fall to all three sides only

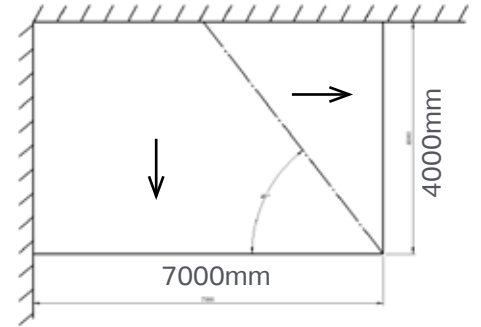

Fall to two sides only

* Any host wall returns need to accommodate soffit size plus 20mm from external brick.

Please see images below for roof configurations that are not possible.

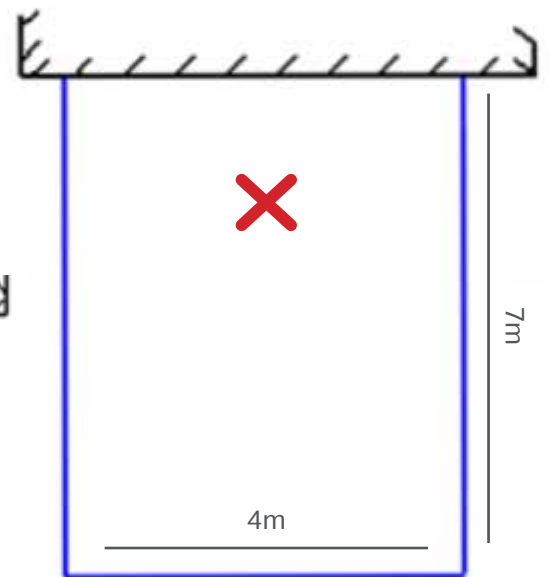
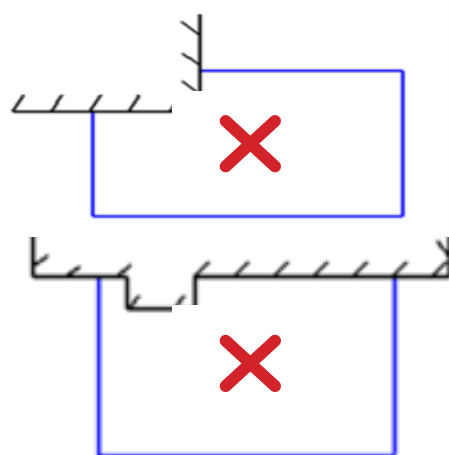
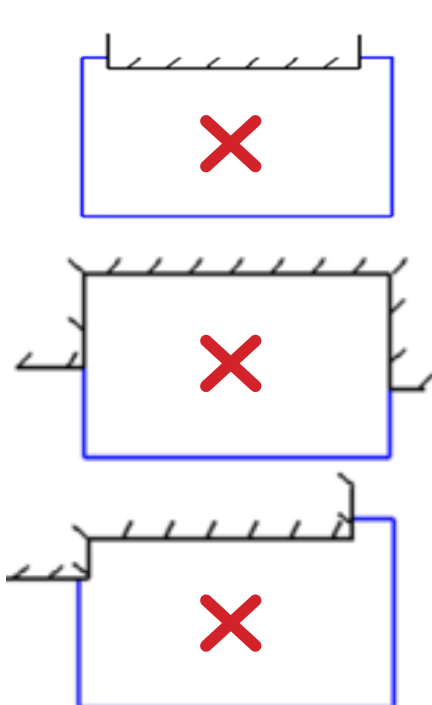

Roof cannot project 7m from Host, max projection is 4m.

Aperture locations

The roof falls to all available sides and can be supplied solid with no apertures or with one or two apertures.

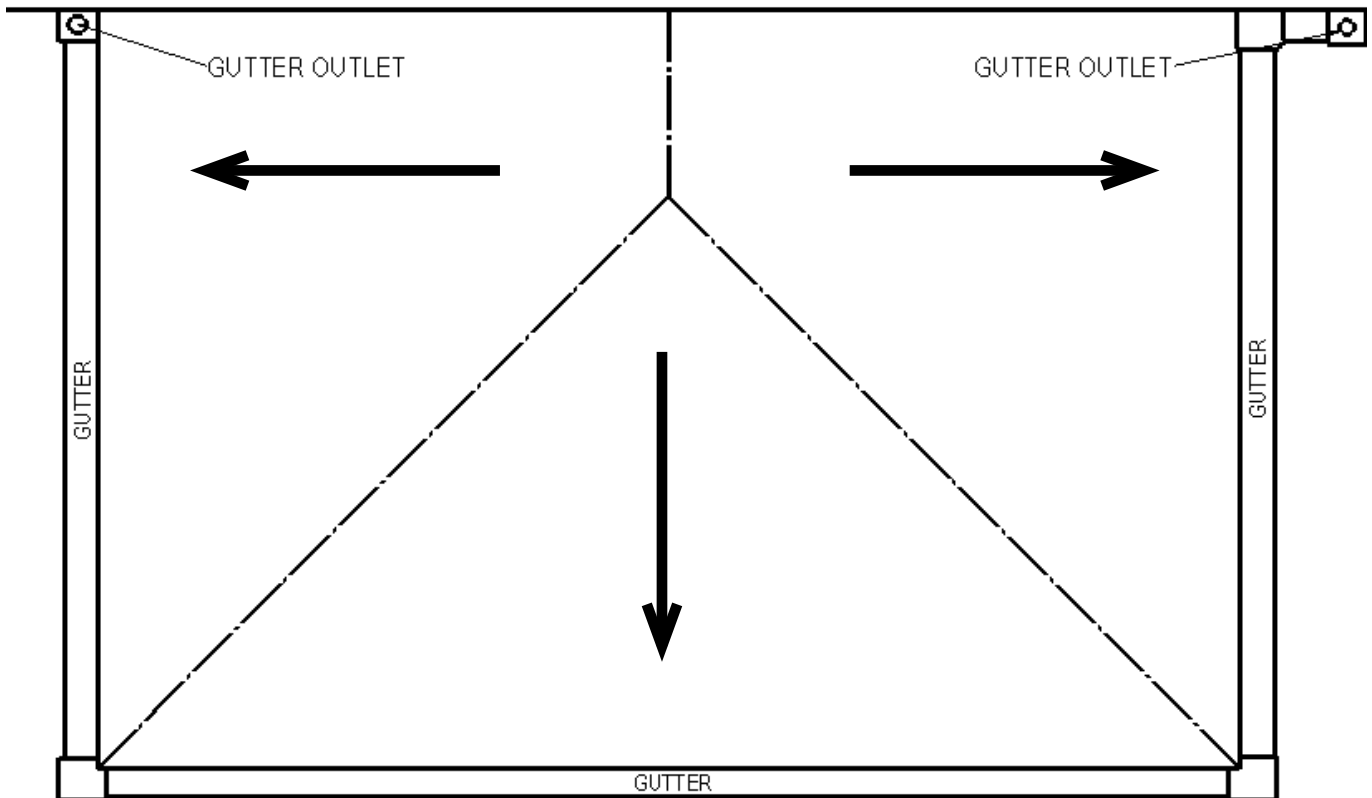

Every aperture must be located at least 300mm away from the internal brick wall on every elevation including the host wall. On elevations with only window and doors, the apertures must be located at least 500mm away from the internal face of the window/ door frame.



If there are 2 apertures the minimum distance between both apertures must be at least 650mm.

Either one or two apertures can be placed in the roof, as shown below. The roof can also be supplied solid without an aperture. Apertures can be located as shown.

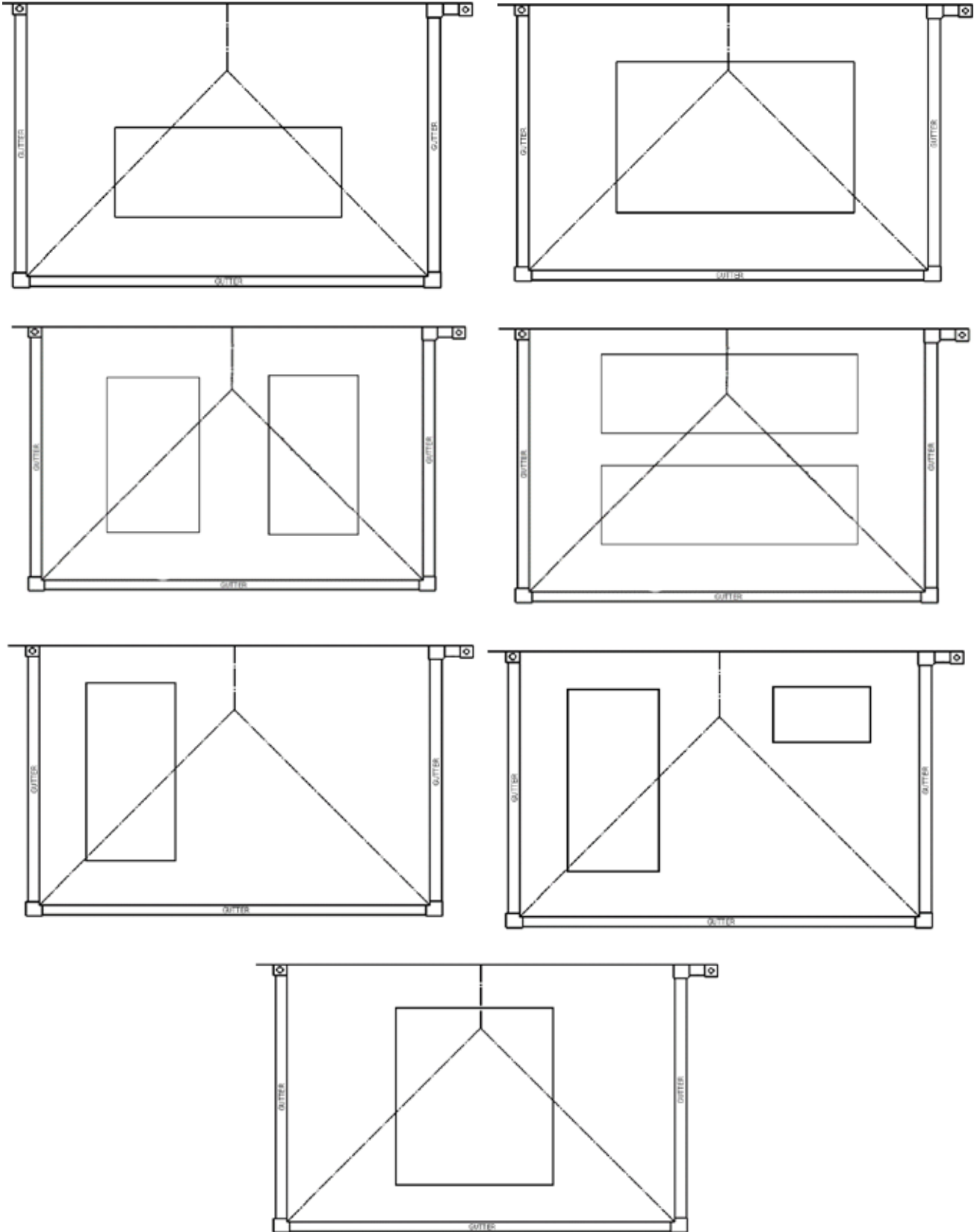

Lantern

Specify your lantern or skylight

Simply specify your lantern and skylights in step two of the order form.

Lantern

The Lantern is available in PVCu or aluminium in any RAL colour and is thermally broken inside and out. With the strongest ridge on the market, the lantern has less bars than other lanterns creating a minimalist look. This combined with a fixed 25° pitch draws more light into the room below, creating a stunning focal point. Lanterns, can be supplied glazed or unglazed.



- 01. Insulated end caps
- 02. Thermally separating top cap clips
- 03. High performance thermal break
- 04. Insulated glazing stops
- 05. Thermally broken eaves rails
- 06. Thermally broken under cladding
- 07. Flat Roof insulated kerb

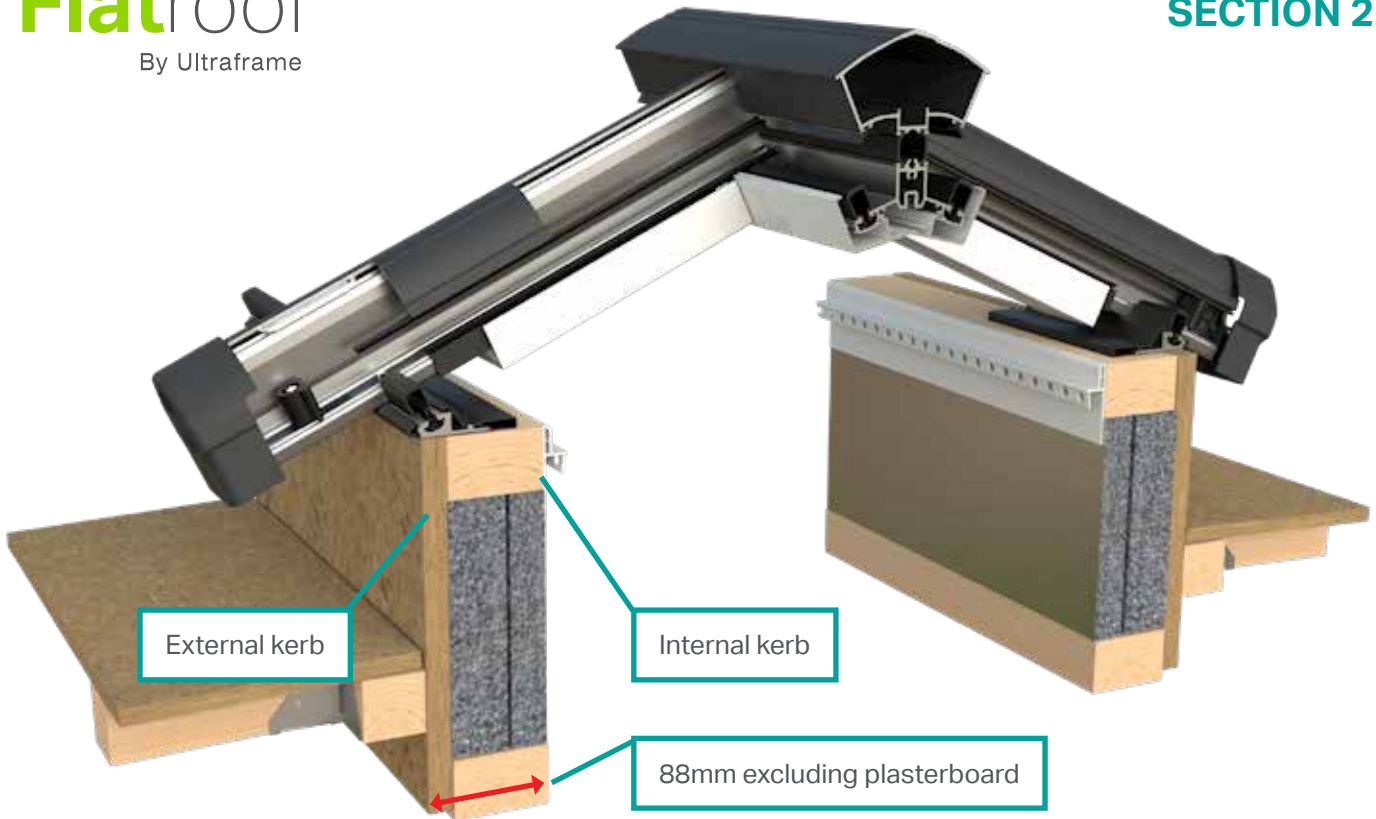

PLEASE NOTE: Maximum aperture size is 5600 x 2900mm measured to the internal of the kerb. You need to add 88mm to each side when ordering lanterns as dimensions are based on external face of the kerb.

Maximum lantern size is therefore 5776 x 3076mm.

Minimum size is 860 x 1360mm.

Glass specifications available

	Tier 4		Tier 3		Tier 2		Tier 1
	Celsius Elite	Conservaglass Ultra86	Celsius One	Conservaglass Ultimate Blue	Celsius Clear	Conservaglass 4S	Conservaglass Standard
U-Value	0.9	1.0	1.0	1.0	1.0	1.0	1.2
Light Transmission	34%	15%	38%	27%	61%	41%	42%
Solar Rejection	83%	86%	83%	80%	58%	67%	60%
UV Protection/ Rejection	94%	90%	94%	90%	73%	86%	83%
Toughened to BS EN 12150-1	✓	✓	✓	✓	✓	✓	✓
Manufactured to BE EN 1279-2	✓	✓	✓	✓	✓	✓	✓
10 year Guarantee	✓	✓	✓	✓	✓	✓	✓
Cleaning	Easy Clean	Self Clean	Easy Clean	Self Clean	Easy Clean	Self Clean	Self Clean
Cavity Fill	Argon	Argon	Argon	Argon	Argon	Argon	Argon
Warm Edge	✓	✓	✓	✓	✓	✓	✓
24mm* (4-16-4)	✓	✓	✓	✓	✓	✓	✓
Colour tints	Blue	Azure Blue	Blue	Blue	Neutral	Blue, Neutral, Aqua, Bronze	Blue, Neutral, Aqua, Bronze

Flat Skylight

The Flat Skylight has an aluminium surround in black as standard or is available in any RAL colour by request. Its distinctive sleek, frameless edge-to-edge glass gives a stunning contemporary look that allows the largest possible amount of light to be brought into the room. The skylight comes complete with a tapered kerb which delivers a 4° pitch to prevent water pooling. It is both fast and easy to fit thanks to its click-fit fixing system. The Flat Skylight is available in a number of square or rectangular sizes ranging from 600mm to 2500mm in length.



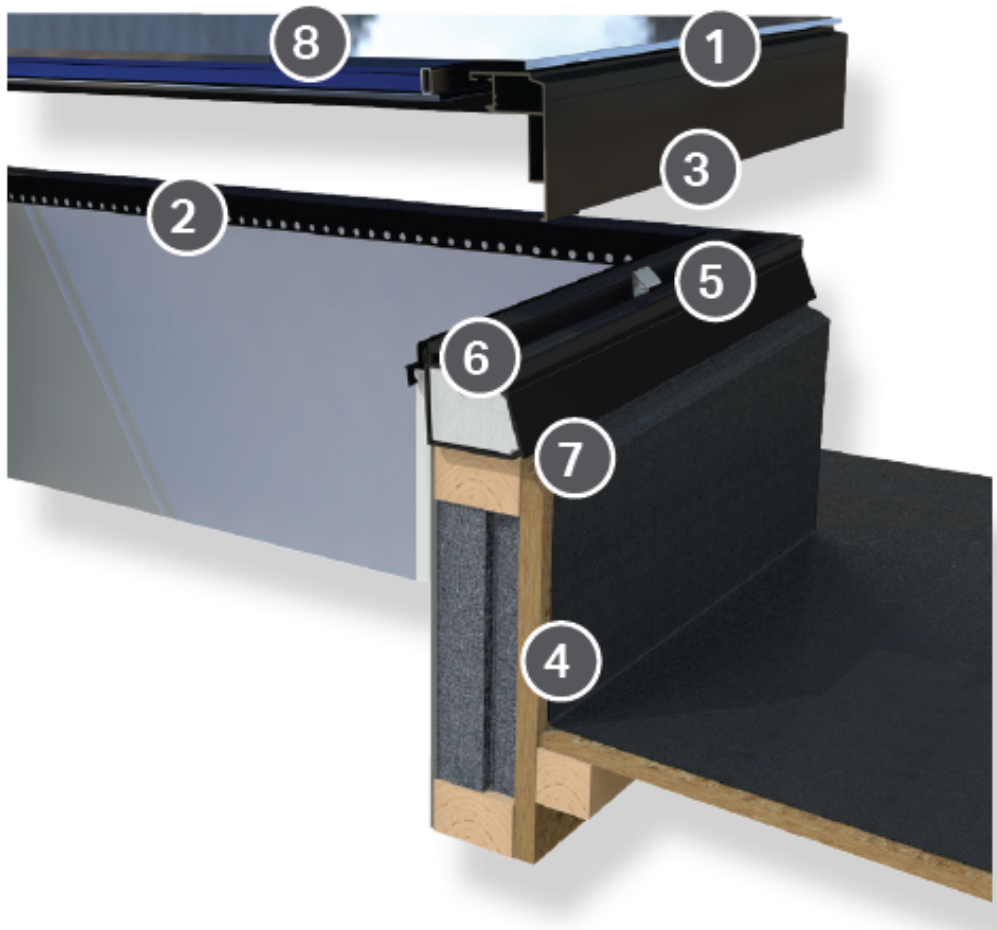

Flat Skylight

- 01. Edge-to-edge glass for a contemporary look
- 02. Fine line plasterboard trim for a neat internal finish
- 03. Slim aluminium surround blends seamlessly with glass
- 04. Tapered kerb to deliver a 4° pitch
- 05. Click-fit clips for quick fitting first time, every time
- 06. High compression double seal gaskets
- 07. Fully insulated frame with 'Warm Frame' technology
- 08. Noise reducing glass - reduces noise by up to 34db

Soffit options on brick and frame

The Flat Roof is available with two different soffit widths. Choose the same soffit all the way around or a combination of both.

Standard soffit



Extended soffit



Soffit dimensions



Standard soffit
with an overhang
of 36mm from the
external face of the
brick (Excluding
fascia).



Extended soffit
with an overhang
of 240mm from the
external face of the
brick (Excluding
fascia).

Fascia and soffit choices

Choose from a wide variety of fascia options, all available in white as standard or in any RAL colour specified. The roof can also be supplied without fascia.

Fascia options on brick wall and frames

All fascias are supplied complete with Marley gutter system and a round downpipe. Classic fascia kits are supplied with PVC fascia board, decorative profile and soffit board. Cornice fascia kits are supplied with a grey gutter, aluminium cornice profile, PVC fascia board and soffit board. Soffit board can be specified in a different colour to the cornice, to create a slimmer roof look.

Standard soffit



Extended soffit

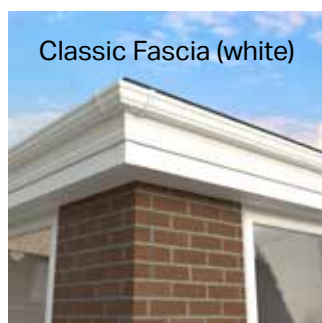

Soffit and fascia dimensions on brick wall and frames

The Flat Roof can be used with any width of brick wall or frames. The standard soffit fascia board is always 52mm from the external face of the brick and 82mm from the external of any frames (including 16mm fascia board). The extended soffit fascia board is always 256mm from the external face of the brick and 286mm from frames.

Standard Soffit

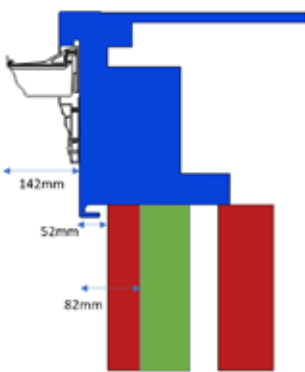

Classic Fascia

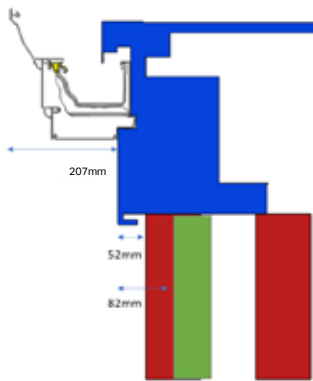

Curved Cornice

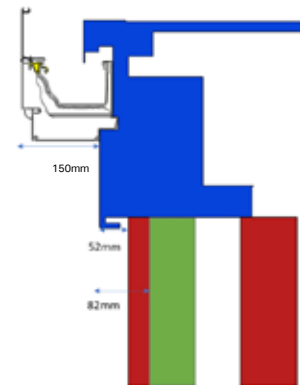

Flat Cornice

Extended Soffit

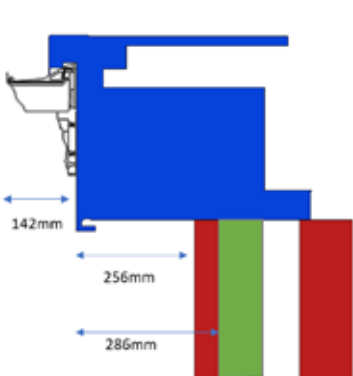

Classic Fascia

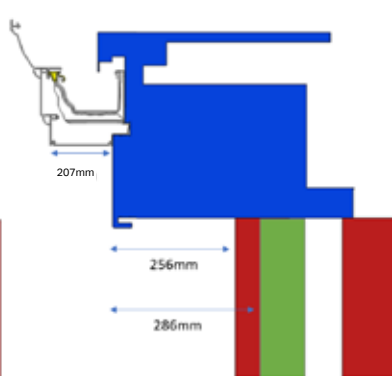

Curved Cornice

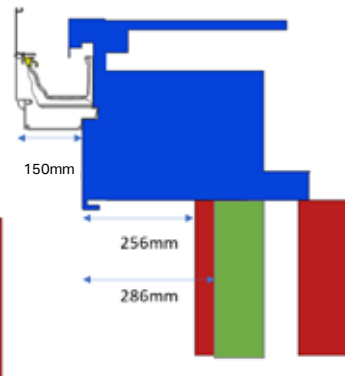

Flat Cornice

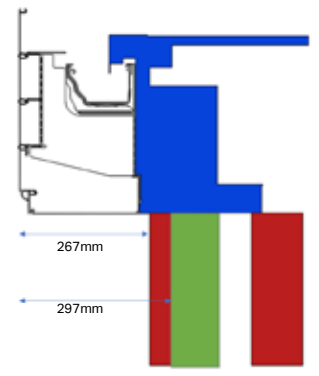

Four Tier Cornice

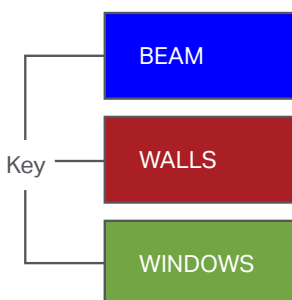

These sizes includes any outlets, corners or jointers.

Outlets

- Outlets can be placed anywhere around the roof
- Round downpipe supplied as standard
- The roof falls to all sides so gutter must be used on all sides
- We can provide these fascia options or you can provide your own
- Please specify which fascia option you would like

Two Tier Cornice



Four Tier Cornice



Classic Fascia



External lighting

External lighting within the roof is only available on the extended soffit (excluding four tier cornice). Lights to be positioned in the soffit as shown in accordance with the manufacturers guidelines. Lights are not supplied.

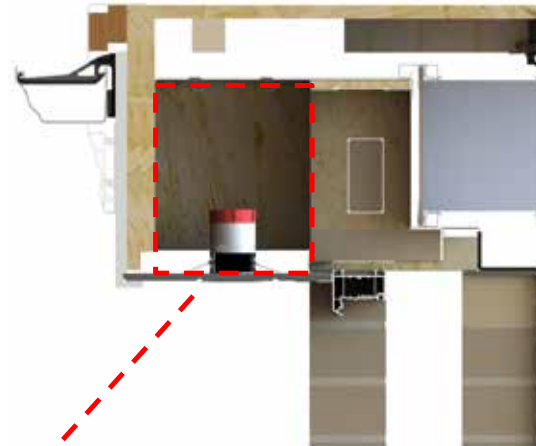

204mm Width
220mm Height

Internal lighting

Internal lighting can be placed below the vapour control layer, within the plasterboard, as shown below. Please refer to your chosen light installation guide for fitting and adhere to Building Regulations.

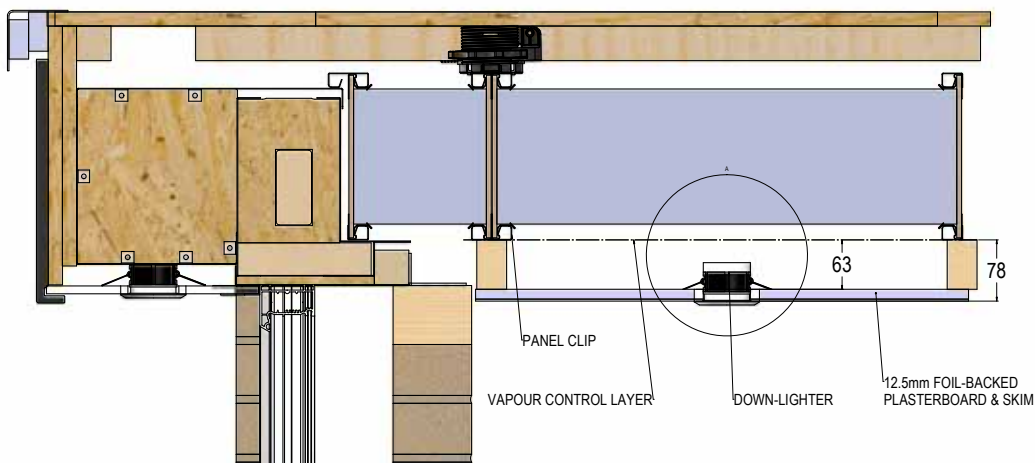

Ceiling heights

Because the underside of the Flat Roof needs to be plaster boarded, please take care to ensure window frames are suitable to avoid the plasterboard interfering with the window. The diagram shows how plasterboard interacts with a 40mm frame.

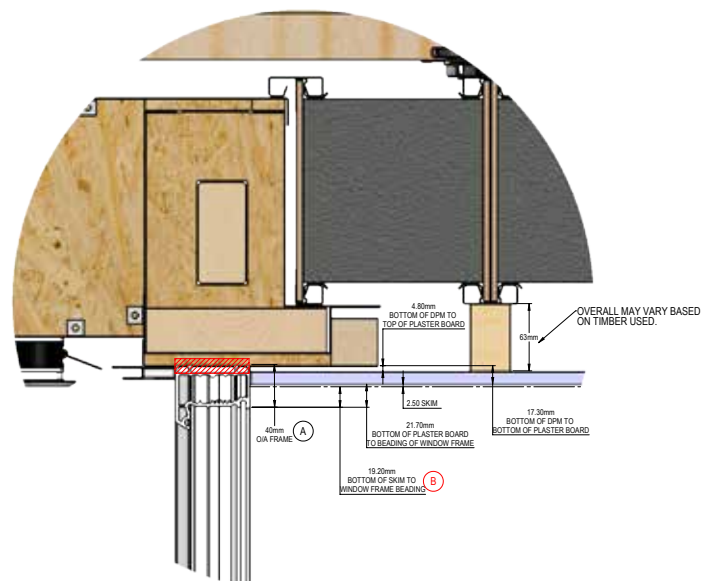

Using the Flat Roof as a conservatory replacement roof

Changing the roof on a previously exempt conservatory from glazing to solid panels means that you have changed the status of the structure.

The new roof is seen as an improvement and with a U-Value of 0.14 W/m² K complies with thermal requirements of Building Regulations, however, there is a caveat - The replacement roof should not make the condition of the existing structure worse – this relates to the ability of the existing side frames and foundations to carry the additional loads imposed by the solid roof. It is necessary to undertake some structural checks that MAY lead to additional site works.

Adequate support from the existing structure is required in three main areas:

1. Window frames
2. Mullions/corner posts
3. Foundation

PVCu window frames

The primary fixing method of the roof is at the house wall and through the head of the window frames and into the beam. When fitting Flat Roof onto the existing frames, the side frames may need de-glazing to allow fixing of box eaves beam. Use bay pole fixings or similar at 450 centres and no more than 200mm from each eaves end/corner (not provided).

Corner posts

If at survey stage there is no reinforcement within the PVCu frames, it may be necessary to replace the corner posts. The dead load of a Flat Roof with deep beam is 60kg/m² and a generous snow load is typically a minimum of 60kg/m² (total 120kg/m²).

E.g. on a 7m x 4m roof, the load is 3360kg, which translates to a maximum loading at each corner of 8.2kN.

Using the table to the right, it can be seen that an aluminium corner post of 50mm square hollow section with a 2mm wall will be adequate - generally corner posts will be larger than this. At survey stage it may be difficult to confirm the presence of the aluminium inside the PVCu sleeve until the roof is removed. Assuming new frames are not being installed, it may be advisable to send with the fitters some spare corner posts to swap with the existing.

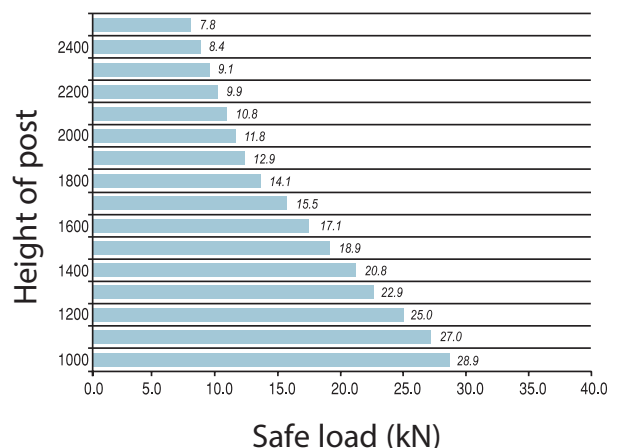
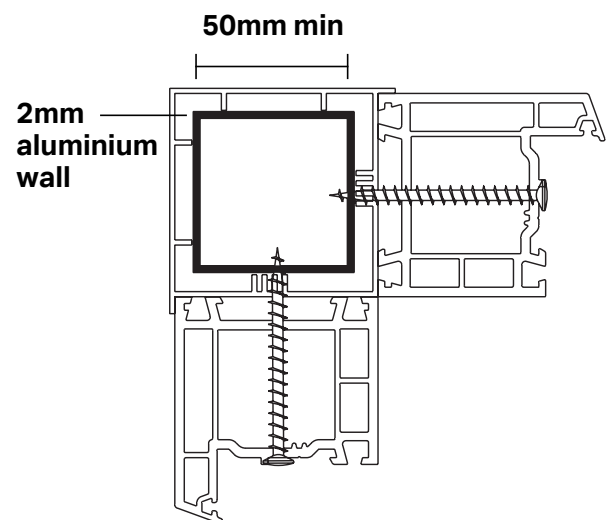

Using the Flat Roof as a conservatory replacement roof

Mullions

An aluminium mullion performs a number of functions, namely;

- act as a wind post to prevent deflection of the frames by wind pressure
- support the roof's eaves beam
- assists with the connection of side frames

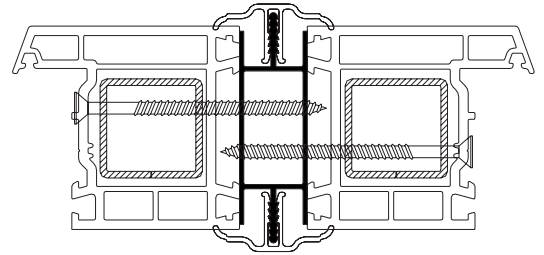

Mullion as a wind post:- the size of the mullion depends on the height of the frame. With full height frames (2100mm) the mullion needs to be the full front to back depth of the window frame and at least 20mm wide.

Adding mullions to existing frames is not really viable – this option should be considered if the consumer has requested new frames/doors. Should the PVCu frames be replaced, the insertion of suitable mullions can remove the need for reinforcement in the frames (as far as structural reasons are concerned) – when using mullions, always place a 20mm washer behind the head of the screw to spread fixing loads.

Foundations

As everyone knows and appreciates, foundation design greatly depends on local ground conditions and advice should be sought from local LABC or an Approved Inspector.

However, there are some rules which are absolute and therefore if the proposed conservatory falls outside this it may be necessary to underpin the existing or remove the existing base and start again. Take up the old foundations if;

- There is an inadequate depth of foundation. The strip foundation **MUST** be a minimum of 450mm and the concrete strip a minimum of 150mm thick.
- There is visible movement between the house wall and the conservatory dwarf wall or cracks in the dwarf wall - this is a clear indication that the foundations are not adequate and also require remedial work.
- On new build projects the footing depth should be that of the house.

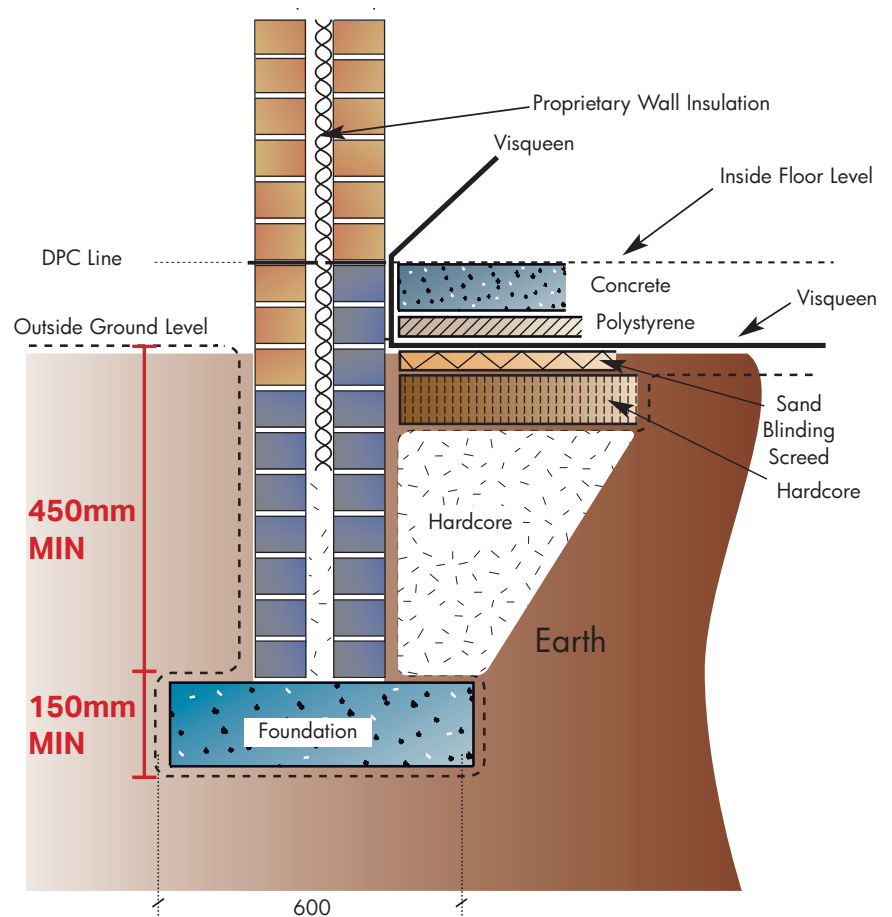

Remediation work (mini piling etc.) can be undertaken cost effectively – Ultraframe recommends **QUICKBASE 0845 644 0000** if you wish to pursue this option.

IF IN DOUBT ABOUT STRUCTURAL COMPLIANCE, PLEASE CONSULT LABC, OR A STRUCTURAL ENGINEER.

The installation of cavity trays above solid roof extensions is always regarded as 'best practice'.

Elevation detail & structural posts

The Flat Roof is strong enough to support downward forces across openings as outlined in the table below. These are the maximum door spans available with this product.

Max opening sizes	Front elevation (mm)	Side Elevations (mm)
Standard Soffit	5670	3220
Extended Soffit	5246	3220
4 Tier Cornice	5246	3220

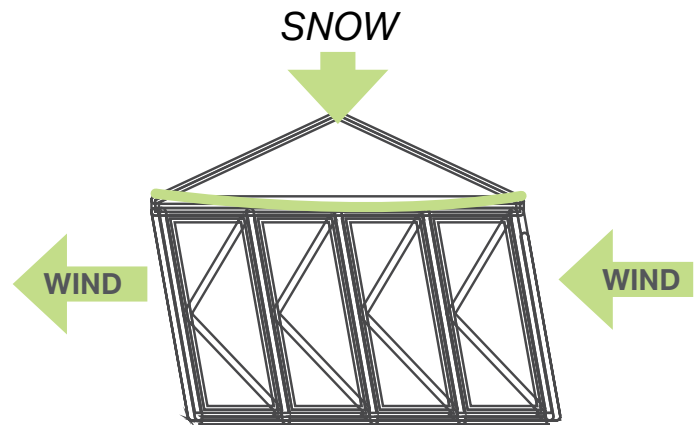

To ensure your building can withstand vertical and lateral forces from extreme weather, you should always ensure there is sufficient structural support in your extension design.

Front Elevations:

The roof also requires a fixed structure at both ends of the front elevation to ensure lateral stability issues and avoid racking. There are three options to choose from:

- Brick pillars designed and sized in accordance with Building Regulations Document A - typically between 665mm and 777.5mm.
- Window returns should be a minimum of 500mm. Frames should be fixed, fully packed and reinforced.
- 100 x 100mm structural post (This can be ordered from Ultraframe if required).

In addition, if the opening on the front elevation is over 3500mm, the opening requires an additional fixed structure at each end of the opening when it does not meet the fixed structure already in place at the front corners. You can choose from the following:

- Brick wall or column
- 100 x 100mm post (This can be ordered from Ultraframe if required)
- 70 x 70mm post (This can be ordered from Ultraframe if required).

Structural Support: Standard soffit examples



With the standard soffit the largest front door set possible is 5670mm shown here centred with brick walls either side.

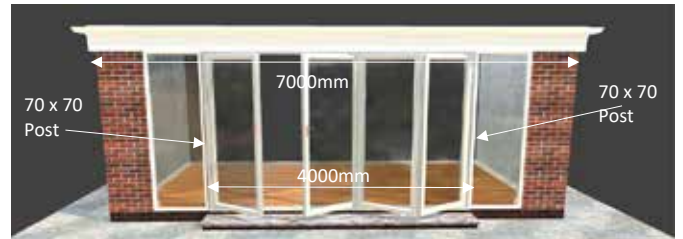

To maximise glazing along the front, 665mm pillars are used. A 70 x 70mm post is needed either side of the doors because the opening does not go straight into the pillars.



With the standard soffit the largest front door set possible is 5670mm shown here centred with brick walls either side.

Structural Support: Extended soffit examples



The largest front door set possible with the extended soffit is 5246mm centred with brick walls either side.

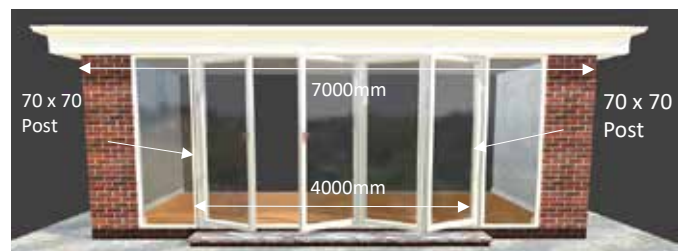

Because this 4000mm door set does not go straight into the 665mm pillars, a 70 x 70mm post is needed either side of the doors.



The maximum available door span on the front with the extended soffit is 5246mm. Here it shown with 712mm window frames either side of the door frame and 70 x 70mm posts set behind the door frame.



When the door span is less than 3500mm, no additional posts are required.

Side elevations:

A fixed structure is required at the end that meets the front elevation. There are three options to choose from:

- Brick pillars designed and sized in accordance with Building Regulations Document A - typically between 665mm and 777.5mm.
- Window returns should be a minimum of 500mm. Frames should be fixed, fully packed and reinforced.
- 100 x 100mm structural post (This can be ordered from Ultraframe if required).

If you have an opening against the host wall then the opening needs to be 50mm away from host wall. This can be completed with a 50mm timber batten (not supplied).



At the largest possible 4m projection the maximum door span on the side elevation is 3220mm.

With a 50mm timber packer at the host wall the wall return shown here is 730mm.

Structural disclaimer: Ultraframe does not take responsibility for the structural stability of the entire structure, only the products provided by Ultraframe. To ensure the rest of the structure is suitable, it is the installer's responsibility to ensure that all walls, foundations and building structure are compliant with Document A of Building Regulations. Any window frames must be a minimum of 70mm reinforced PVC frames, coupled in accordance with the manufacturer's recommendations. Host walls must be suitable to take the additional load and forces of the new building. Foundations or floor slabs must be designed to accept the additional forces.

Structural posts

Structural posts provided as alternative to brick piers. Two sizes of compatible structural posts can be supplied by Ultraframe if required. The 100 x 100mm posts should be used at the front corners of the building and the 70 x 70mm can be used in line if needed at the ends of door frames. The maximum loads are shown in the table below:

Post options	Maximum loads
70 x 70mm posts	Approx 20kN axial
100 x 100mm posts	Approx 60kN axial

The following diagram show where the posts and base plates should be placed in different situations.

Corner post - 100 x 100mm – Slider to Window

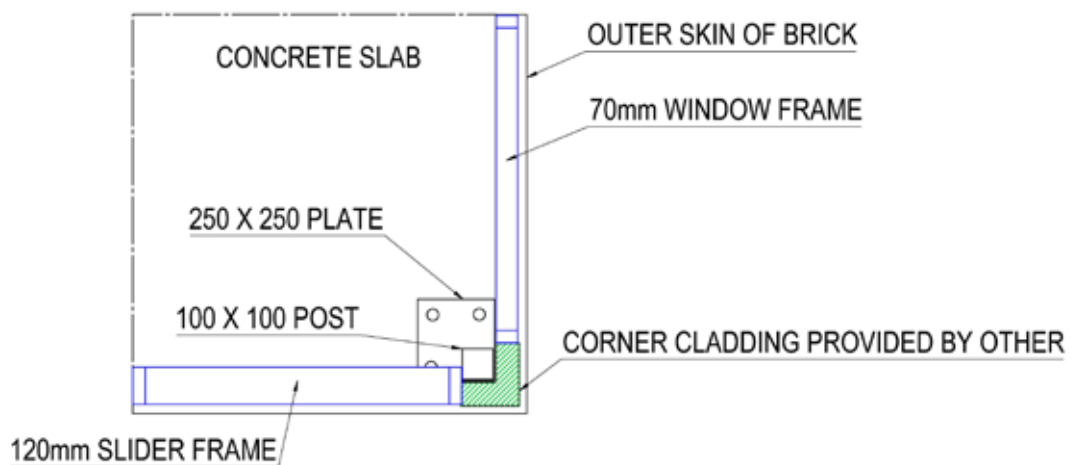

Corner post - 100 x 100mm – bi fold to bi fold

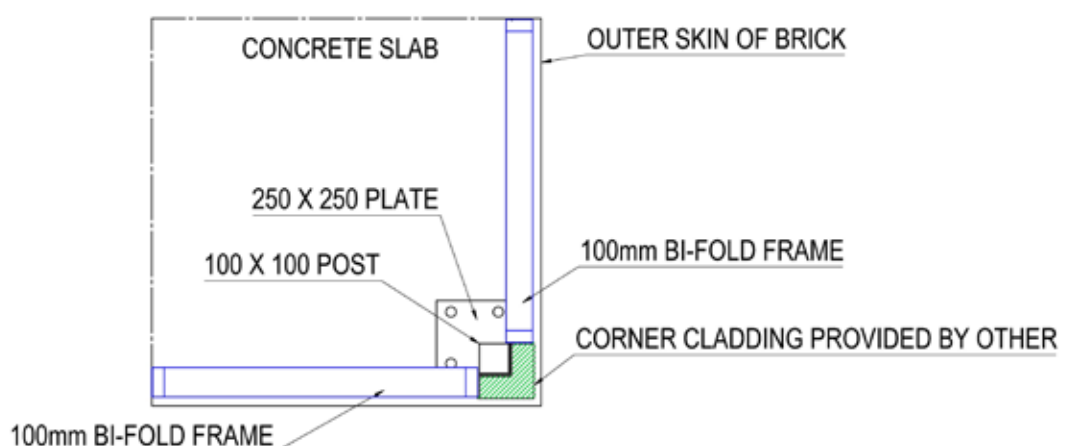

Corner post - 100 x 100mm - Bi fold to window

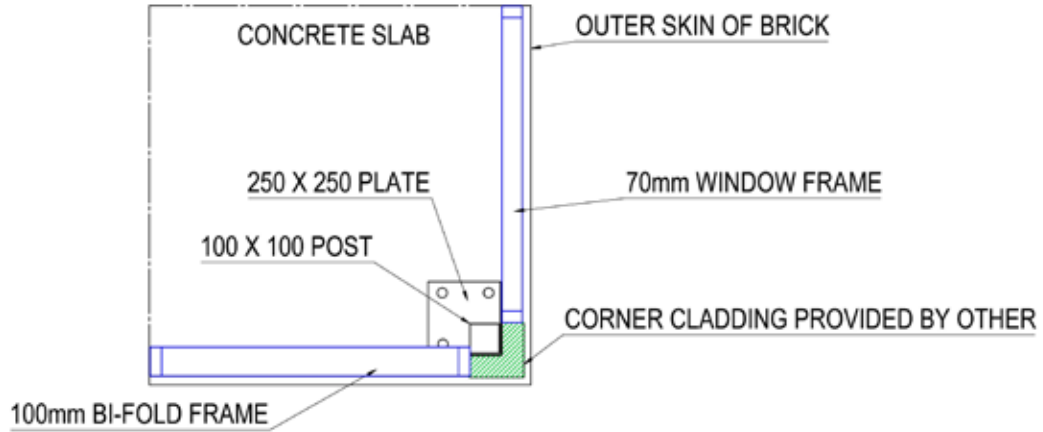

Corner post - 100 x 100mm - Window to window (70mm frames)

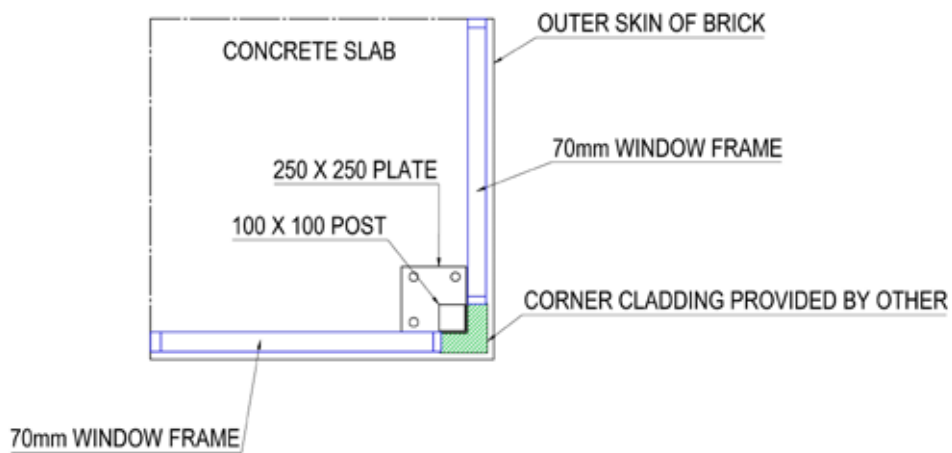

Inline post - 70 x 70mm - Bi fold to window

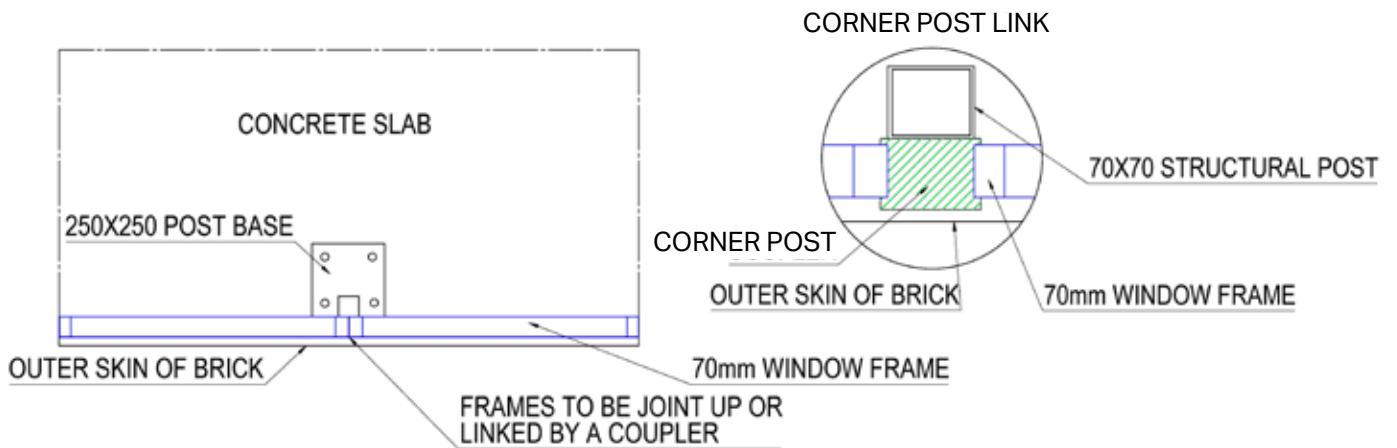

How to calculate your roof height

The roof pitch is set to 1°. For every metre of fall, add 17.5mm to the top of the OSB deck.

Once all components are assembled, the lowest point of the roof will be 346mm above the eaves height on a standard beam and 420mm on a deep beam. Examples shown below.

In the majority of cases, a standard beam will be required, but when extra structural support is required, a deep beam may be needed. The beam required will be confirmed on your order confirmation.

Standard Beam



$$407 - 346 = 3.5 \times 17.5$$

Deep Beam



$$481 - 420 = 3.5 \times 17.5$$

Note: Always check the beam specification on your order confirmation before calculating where the cavity with trays need to be located.

Membrane compatibility

The Ultraframe Flat Roof is not supplied with a waterproof membrane or drip edge detail. The system is compatible with most roof finishes such as GRP, EPDM or PVC membranes. Membranes must be suitable for use on the OSB318, so please check with your membrane supplier.

The OSB deck on which to lay the membrane finishes 80mm beyond the OSB fascia to accommodate a variety of drip edge details.

GENERAL

- | | | | |
|--------------------------|---|--------------------------|--|
| <input type="checkbox"/> | 1. Is planning permission needed?
If yes, who will apply? | <input type="checkbox"/> | 14. Ensure there is enough room above the Flat Roof to lead flash? |
| <input type="checkbox"/> | 2. Is there sufficient access to the proposed building? Including height and width restrictions for delivery of material, frames, glass & welded cills etc? | <input type="checkbox"/> | 15. Will the Flat Roof overhang a boundary wall?
With a standard soffit Flat Roof is 56mm wider than a standard conservatory roof on both sides and 202mm wider when the extended soffit is used. See page 16 for details |
| <input type="checkbox"/> | 3. Will construction involve crossing any public or neighbours path, garden, wall or hedge? | | |
| <input type="checkbox"/> | 4. Will you need a skip on site? | | |
| <input type="checkbox"/> | 5. Are there plants, bushes, trees, sheds, fish-ponds in the way? | | |
| <input type="checkbox"/> | 6. Are there any other visible obstructions on the ground? | | |
| <input type="checkbox"/> | 7. Is the house wall sufficiently out of plumb to require any allowance in the design of the roof? | | |
| <input type="checkbox"/> | 8. Are there any signs of settlement or hairline cracks in the house wall - have these been pointed out to the customer? | | |
| <input type="checkbox"/> | 9. Is there a soil vent pipe, RWP, extractor fan or gas flue in the way of the proposed roof?
Please note the Flat Roof will only accept intrusions up to 266mm | | |
| <input type="checkbox"/> | 10. Are there any existing window or door openings to be moved, altered or bricked up? | | |
| <input type="checkbox"/> | 11. New openings to existing property will require new lintels which will require building regulation approval. Fitting Flat Roof does not guarantee the removal of separating doors. | | |
| <input type="checkbox"/> | 12. Are there any existing window or door openings to be included within the newly proposed extension? | | |
| <input type="checkbox"/> | 13. Is there a height restriction above the proposed roof ie. a bedroom window? | | |

REPLACEMENT

- 1. Are there any "hairline cracks" within the existing base and walls to establish whether the existing structure is sound.
- 2. Are the existing window frames in good condition or is there, for example, evidence of cracking welds within the frames.
- 3. Will existing cavity trays and flashing need to be moved? Please see page 26 for details.
- 4. Does the Corner have reinforcement?
- 5. How far from the underside of the beam is the glazing line. If less than 40mm, then additional packing will be required.

NEW BUILD

- 1. Are there any existing structures to demolish?
- 2. Is there an existing patio or path to be removed?
- 3. Is there an existing retaining wall - will this need re-constructing?
- 4. Are there any projecting bell casts, soldier courses, key stones in the way?
- 5. Are there any TV, satellite or telephone cables in the way?
- 6. Are there air bricks or head ventilators in the existing extension?
- 7. What is the existing external wall finish - Facing brick, stone, render or pebbledash to match to?
- 8. If facing brick, is a cavity tray required?
- 10. Are there any existing underground drainage pipes to be moved or built over?

NEW BUILD

- 11. Is there an existing manhole to be moved or raised to the new extension floor level then sealed with an airtight cover? Or seek 'buildover' agreement if applicable.
- 12. Are there any pipes or cables to be catered for in the proposed build?
- 13. Will the difference in house floor level and the proposed new extension floor level require steps?
- 14. Will the difference between the proposed new extension floor level and the outside ground floor level need a landing, steps and handrail?
- 15. Is a dwarf wall required - what height?
- 16. Are there squint bricks or stone quoins required or will you cut and bond bricks?
- 17. Are there any new openings required in the proposed basework for doors?
- 18. Is the site sloping away requiring extra height to the basework?
- 19. Is the site sloping towards the basework requiring excavation?
- 20. Will a retaining wall be needed?
- 21. Is a new path or patio area required?
- 22. Check coursing and spacing of brickwork against existing - ie Imperial or Metric
- 23. Is the new extension rainwater to discharge into an existing gully or is a new gully required?
- 24. Is there a sufficient number of rainwater outlets for the size of roof?
- 25. Is there an existing gully to move?
- 26. Has all the detail been discussed and agreed with the customer?

JOB REFERENCE:

STEP 2: MARK YOUR ELEVATIONS AND INDICATE THE FOLLOWING:

Please mark on the drawing plan below

- What the roof is sitting on e.g. frame or brick
- Thickness of frame or brick
- Height of wall - standard eaves height is 2400mm unless specified.
- Opening location and size

If you would like a visual representation of your design, please confirm the colours of your frames.

If structural posts are needed, would you like Ultraframe to supply yes no



Please return to flatroofsales@ultraframe.co.uk

JOB REFERENCE:

STEP 3: SPECIFY YOUR LANTERN / FLAT SKYLIGHT

Lantern

ROOF MATERIALS PVCu White PVCu Painted Grey PVCu Black Aluminium 9003 White 80% gloss Aluminium 7016 Grey 30% gloss Aluminium 9005 Black 60% gloss

External

Internal

BESPOKE COLOUR

PVCu Ali

External RAL: .

Internal RAL:

GLASS OPTIONS - WARM EDGE SPACER

Conservaglass	Ultra86 Blue Bronze 4S	Ultimate Blue	Blue 4S	Neutral 4S	Aqua 4S
Celsius	Celsius One Unglazed	Celsius Elite	Celsius Clear		

ROTABOND SEALANT - MS POLYMER

Black (NCGS001B) No. Tubes Req: N.B. For use with glass

ROOF VENTS AND MECHANISM

Manual with brass Manual with chrome Electric switch/mechanism Electric with rain sensor / thermostat

Flat Skylight

COLOUR: RAL9005 - 60% Black RAL9003 - 80% White RAL7016 - 30% Grey Bespoke RAL:

GLOSS %

GLASS OPTIONS: Standard, 26mm or 28mm (glass size dependent on skylight size) Clear Blue

STEP 4: CHOOSE YOUR SOFFIT

Please specify if you would like standard soffit or extended soffit.

Standard soffit Extended soffit



Standard soffit



Extended soffit

STEP 5: FASCIA OPTION

Please specify what fascia option you would like.

Naked Classic Fascia Curved Cornice Two Tier Flat Cornice Four Tier Flat Cornice (only available on standard soffit)



STEP 5A: PICK YOUR FASCIA COLOUR

Please specify your fascia, gutter and cornice colour.

Fascia and gutter colour White Other:

Cornice colour White Other:

Please note that roof membrane is not supplied and must be ordered separately. The Flat Roof System is compatible with most roof finishes such as GRP, EPDM or PVC membranes.

Please return to flatroofsales@ultraframe.co.uk

Flatroof

By Ultraframe