



QUANTAL

V1 | October 2018

SURVEYORS
INFORMATION

WELCOME

This guide gives specific details on the Quantal system as well as general details on base work layouts, calculations and window frames. There are many aspects to surveying and it is the conservatory designer or surveyor's responsibility to ensure the best design in terms of the structure, the aesthetics and the installation for the site. There is no definitive start point, but the most complicated aspect of the conservatory is usually the roof and therefore should be the first consideration. A good design eliminates additional costs, complexity and provides greater visual appeal. A clear, precise and workable specification is vital to the effectiveness of a project. An error in calculating an angle or size will lead to delays in installation and add additional costs.

Suggested surveying tools: Spirit Level, Tape Measure, Angle Finder, Plumb Line, Calculator, Camera.

CONTENTS

Section 1	Structural design guidelines	03
Section 2	Existing property	04
Section 3	Walls and soffits	05
Section 4	Windows frames / Structural walls	06
Section 5	Design guide - Victorian	07
Section 6	Design guide - Edwardian	08
Section 7	Design guide - Combination	09
Section 8	Base details	10
Section 9	Drainage options	11
Section 10	Roof size with end frames	12
Section 11	Base calculations	13
Section 12	String lines	14
Section 13	Calculating ridge lengths	15
Section 14	Ridge height chart	16
Section 15	LPR ridge height chart	17
Section 16	Profile identification chart	18
Section 17	Glazing recommendations	19
Section 18	Glass sizes	20
Section 19	Combination roofs	21
Section 20	Tie bars – Combination roofs	22
Section 21	Insulated pelmet option	23
Section 22	Patio / Bi-fold doors	24
Section 23	Span charts	25
Section 24	Eaves	26
Section 25	Box gutters	27
Section 26	Adaptors and guttering	28
Section 27	Box gutters	29
Section 28	Ventilation	30
Section 29	Portal frames	31

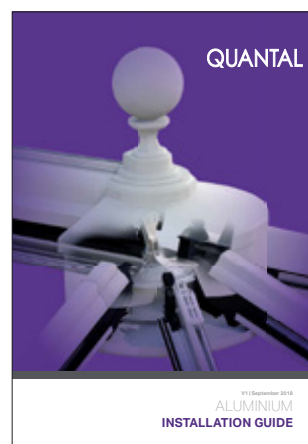

Installation guide

STRUCTURAL DESIGN GUIDELINES

Quantal – wants to ensure that its customers and users are working to the best codes/design standards. Most domestic conservatories are exempt from Building Regulations and so most of the time a conservatory didn't need to comply with BS6399 but each roof is designed to a postcode and is more than fit for purpose (peace of mind). BS6399 has now been superseded by Eurocodes and Quantal is now working to these.

By updating to Eurocodes we are ensuring the roof stay ahead of competitors and continues to be well positioned should for example CE Marking become mandatory on the roof in the future.

Quantal software called U-Design, which is an electronic rule book of structural guidelines called eSDG. The eSDG has been updated to include;

- BreVe (which supplies the weather data inside eSDG) has finally fully adopted the Eurocodes and therefore the wind and snow loading they provide into U-Design has also been updated.
- The wind and snow loads in Eurocode are calculated differently and have also been revised with more updated average wind and ground snow loads in the UK.

Certificate of Authenticity

Conservatory roofs are sent to site with a registration form that the fitter passes to the homeowner, who then registers with Quantal and in return receives a 'Certificate of Authenticity', confirming that they have had the genuine product installed. They also receive a FREE conservatory maintenance manual with hints and tips on how to care for the new conservatory.

As part of our philosophy...

We want to make trading between our trade partners and us, easy and error free. That's why our vision is to receive orders electronically from our trade partners. In fact, we encourage our partners to design a conservatory in the home or showroom, structurally prove it and 'fire it' through for computerised manufacturing, virtually untouched by human hands!

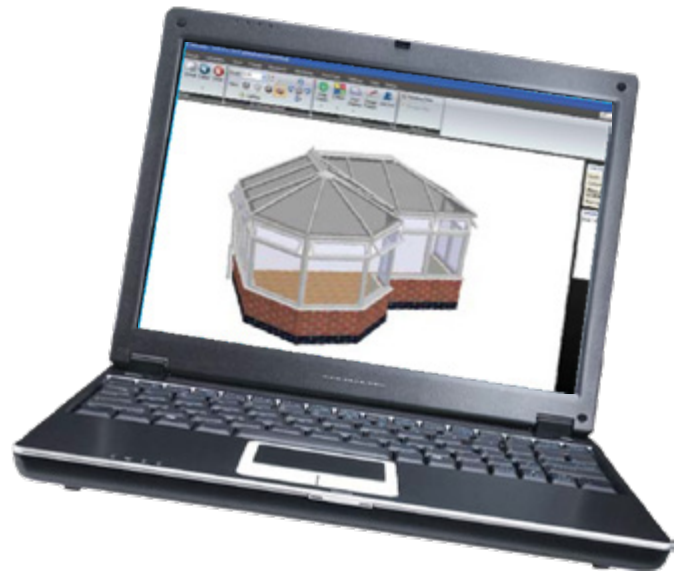

U-Design software visualises and designs conservatories. We rigorously tested our roof and alternatives - ask for the DVD of the aero engine at the Wintech Test Centre.

ADDITIONAL NOTES:

1. This means that roof projects are now more accurately specified for loads than before - this does not mean that we were wrong before just that we have improved the way the loads are calculated based on the latest information available.



Quantal brochure

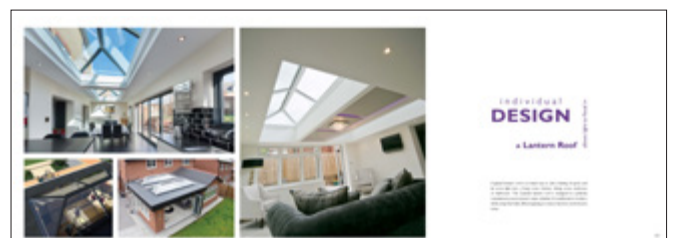

EXISTING PROPERTY

It is essential to check the existing property for existing features that may require addressing before or during installation. For example, these could include water pipes, gas flues or overflow pipes.

To ensure the smooth and efficient installation we have highlighted some of the common situations that if ignored or are not taken into consideration could lengthen, delay or possibly stop the project at any stage.

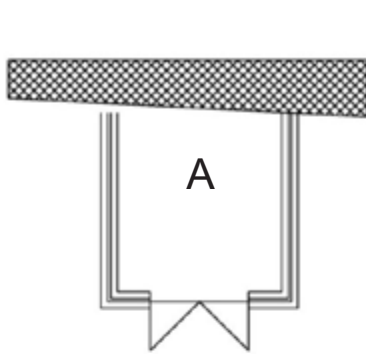

A) Is the house wall level/parallel?

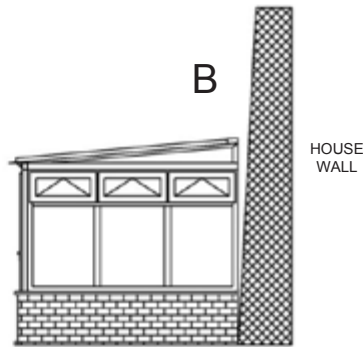

B) Is the house wall plumb?

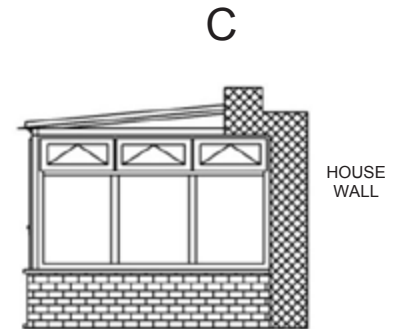

C) Does the upper floor project further than the lower floor?

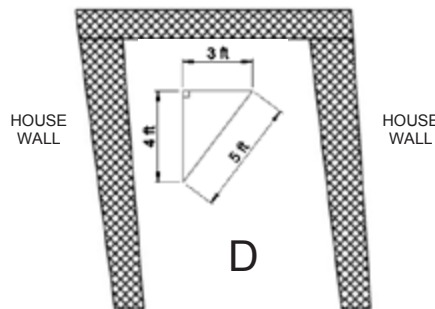
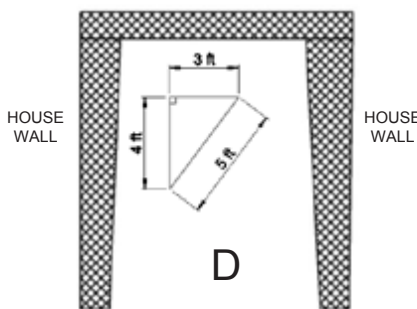

D) Are the house walls at 90° or does the property taper in or out? Use Pythagoras Theorem to determine if walls are at 90°. i.e. 3,4,5 Triangle or $a^2 + b^2 = c^2$ e.g. $3^2 + 4^2 = 5^2$. Note ($\sqrt{5^2} = 5$)

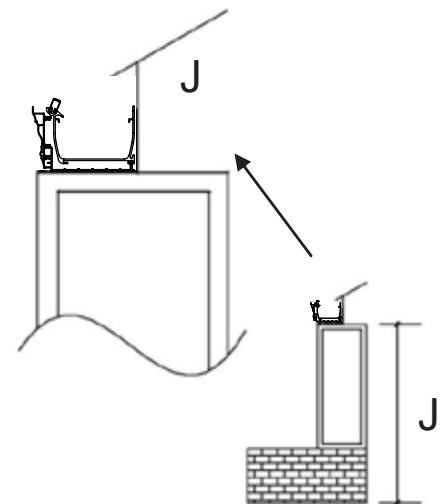

J) Check soffit height from DPC is consistent? Is fascia height sufficient for wallplate or box gutter? Will existing guttering be removed or replaced? Is soffit over hang consistent?

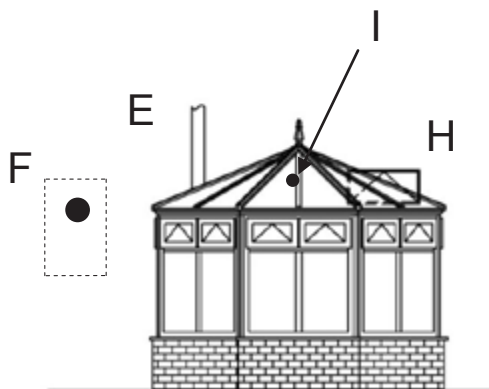

E) Will soil pipe obstruct proposed site? Will soil pipe obstruct any new openings?

F) Will any flue have sufficient clearance and not create any obstructions to proposed conservatory or conservatory openings?

G) Will overflow pipe have to be repositioned?

H) Will the existing opening from the house have sufficient clearance?

I) Will horizontal tie bar rod locate above existing opening and lintel? Will any conservatory openings obstruct

WALLS AND SOFFITS

To provide privacy from neighbours one or more of the walls could be heightened, if so consideration to the void created is required. On combination roofs the returns require thought to maintain the aesthetics and ensure the openings are unaffected. When box gutters and/or soffits are involved with the roof consideration must be given to the roof projection compared to the base projection and also rafter positioning.

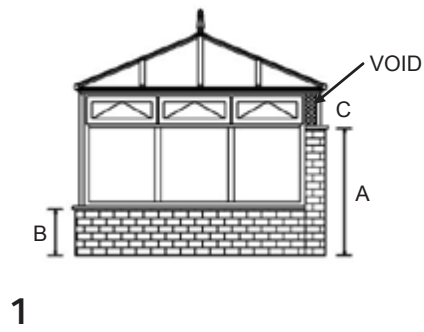

Dual wall heights

- A) Wall height at 1500mm
- B) Wall height at 600mm
- C) A void is created by the width of the brick and cavity, which needs to be addressed.

1

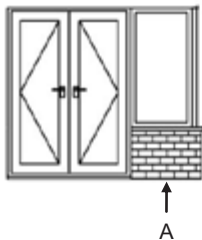
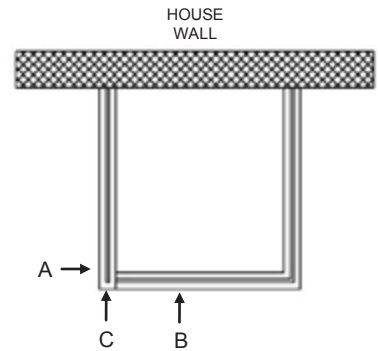

Corner return with opening

- A) Leave sufficient space so the window cill does not obstruct the door to open.

2

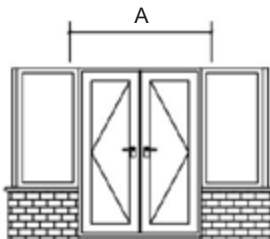
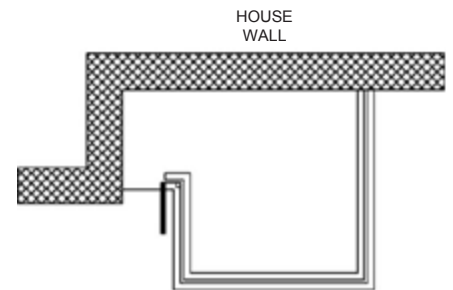

Opening with two returns

- A) The door opening will be less than the internal dimension between the two main due to cavity walls, i.e. internal dimension of 3 metres will reduce by the width of both external bricks. This will create two voids similar to 1C.
- B) Beware the projecting window cill could obstruct the doors from opening fully.

3

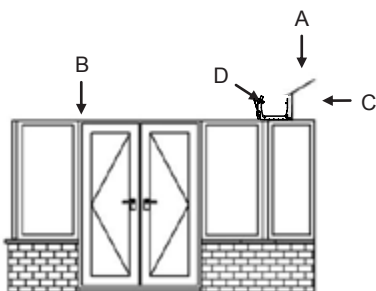
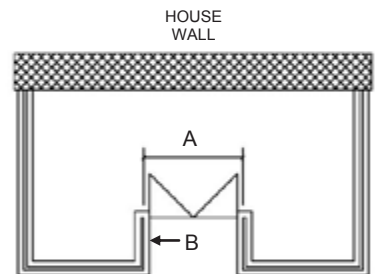

Box gutters & soffit

- A) The roof projection will be reduced by the depth of the box gutter and/or soffit
- B) Consider the window frame spacings in relation to the roof spacings when a box gutter and/or a soffit situation arise An option is to place a window frame or brick pier to fill this area
- C) Soffit
- D) Box gutter.

4

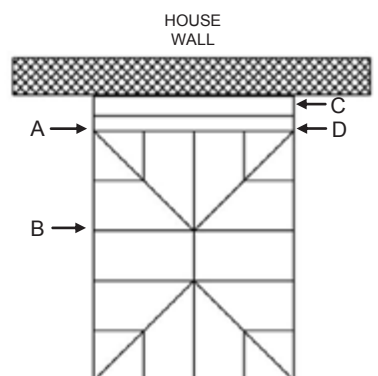

WINDOWS FRAMES / STRUCTURAL WALLS

The structural integrity of the conservatory must not be reliant on the window frames alone, as PVCu windows (even reinforced ones) are not designed to carry the dead load of the roof and the live loads of wind or snow upon it, which must be transmitted through structural mullions and corner/bay posts. Even a modest sized roof may have a weight of 0.5 tonnes (equivalent to 6 people standing on it) plus the imposed loads. Consideration of the other items below is also necessary at the surveying stage.

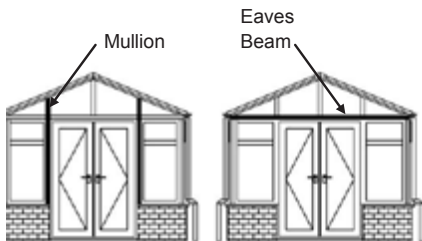

Frame coupling

A) On angled or gable frames it is recommended that the structural mullions be positioned vertically. Alternatively an eaves beam and cill can be used across the front of the Gable..

B) It is also recommended to connect the frames with structural mullions evenly at approximately 2 metre intervals to avoid excessive pressure being applied to the window frames.

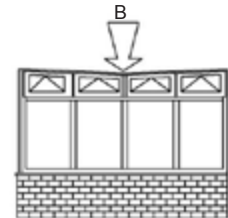

1

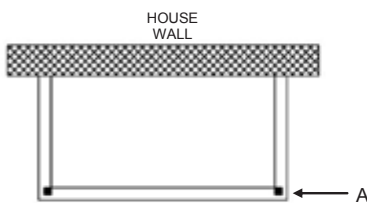

Window cills

A) The window cill should be reinforced and contain a load bearing kit at each corner facet.

B) On longer facets additional kits are recommended at the position of the structural mullions.

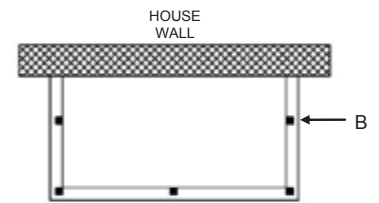

2

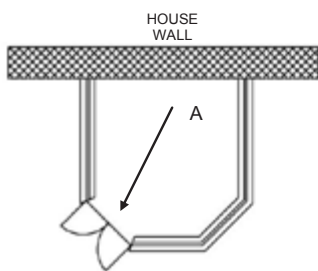

Door positioning

A) Creates a corridor effect through the conservatory.

B) Optimise the floor area by positioning the doorway close to the house opening or doorway.

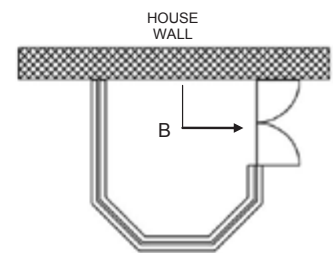

3



Rainwater pipe positioning

A) Positioning the rain water pipe from the box gutter over a window looks unsightly and the pipe could obstruct any openings.

B) At the house wall the pipe could obstruct the opening window. Use of a frame extension can alleviate this problem.

C) It is recommended that additional outlets are required over 33m² of roof area.

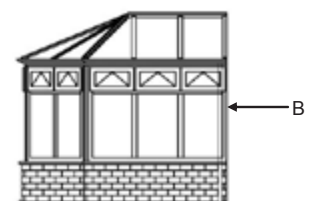

4

DESIGN GUIDE - VICTORIAN

When designing the roof, common facet sizes and angles will give improved looks, easier manufacture and installation. Similarly a common roof pitch to all roof sections will give an improved fit, finish and weathering.

The best conservatory roofs are symmetrical designs.

Preferred design

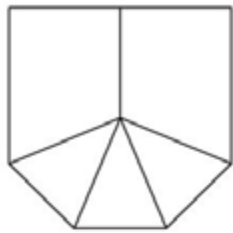

Equal facet sizes around the front bay.

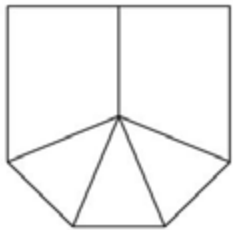

Standard 135° to all internal angles around the bay.

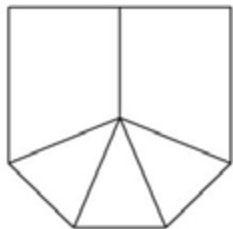

Equal pitches on all roof sections gives improved aesthetics.

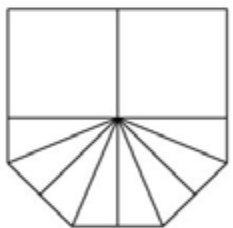

Rafter bar to rear of gallery gives equal glazing panels. Improved weathering to rear of gallery.

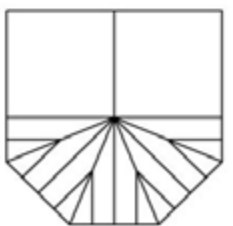

Use jack rafters when more than 9 bars to the gallery. Rafter bars are 90° in relation to eaves beam.

Less preferred design

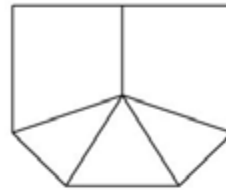

Non equal facet sizes.

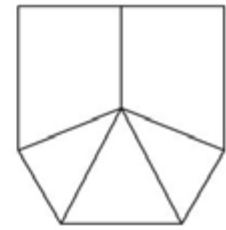

Non standard internal angles around the bay.

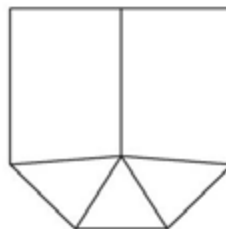

No bar to rear of gallery increases glazing costs especially to glass.

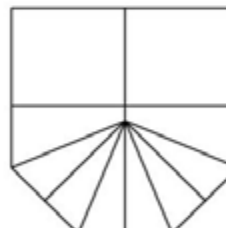

Avoid fanned rafters when more than 9 bars to gallery. Avoid fanned rafters as this increases costs.

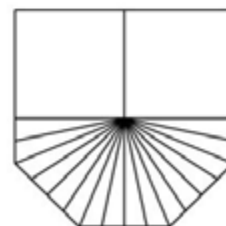

Maximum 13 rafters to gallery area.

DESIGN GUIDE - EDWARDIAN

When designing the roof, common facet sizes and angles will give improved looks, easier manufacture and installation. Similarly a common roof pitch to all roof sections will give an improved fit, finish and weathering. Jack rafters will meet at the same point along the hip bar assuming common bar centre spacing.

The best conservatory roofs are symmetrical designs.

Preferred design

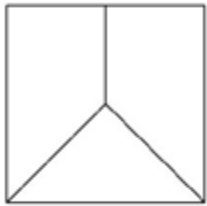

Keep equal pitches on all roof sections.
Keep the hips at a plan angle of 45°.

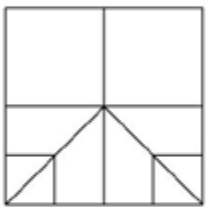

Align jack rafters for improved aesthetics.
Rafter bars are 90° in relation to the eaves beam.

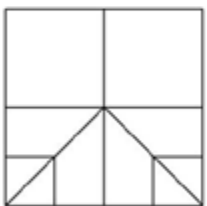

Rafter bar to rear of gallery gives equal panels and easier glazing. Ideally there should always be 1 bar to the ridge.
Improved weathering to rear of gallery.



No ridge provides easier assembly and structural stability.

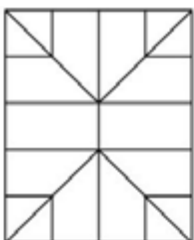

Minimum ridge length of 400mm allows creasting and improved aesthetics.

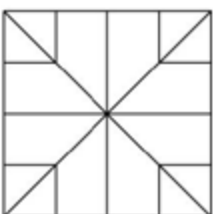

If the ridge length is less than 400mm use Gazebo roof style.

Less preferred design

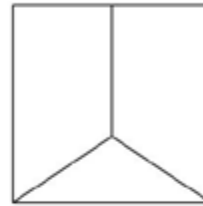

Stretched ridge or unequal roof sections can increase costs.
The hip does not sit over eaves corner correctly.

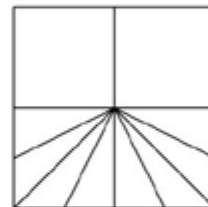

Try to avoid fanned rafters as the rafter bar end caps are not parallel to eaves.
Can increase costs.
Maximum 13 rafters to gallery area.

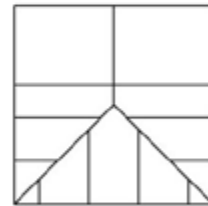

Jack rafters not aligned giving poor aesthetics.

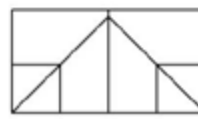

Minimum ridge length of 600mm. Ideally there should always be 1 glazing bar to the ridge. Tie Bar is required.

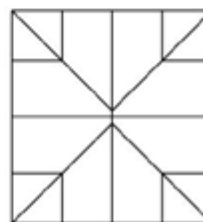

Finials are too close together giving poor aesthetics and no creasting.

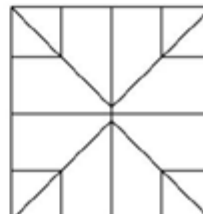

DESIGN GUIDE - COMBINATION

When planning combination roofs the same principles apply as outlined in the previous sections. It is best to design the roof for optimum glazing performance and considering the position of tie bars is essential. Please read this in conjunction with the Combination Roofs sections.

The best conservatory roofs are symmetrical designs.

Preferred design



Rafter bars are 90° in relation to the eaves beam.



Maximum 7 rafter bars to the corner.

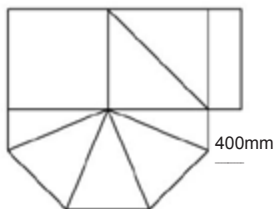

Minimum 400mm return from Victorian to lean-to.
Good rafter position onto valley.
Position for a tie bar.

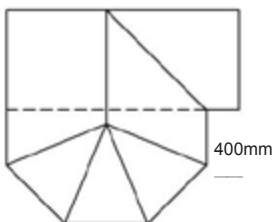

Optimum design as valley bar at plan angle of 45°.
Ridge length 200mm greater than lean-to section.

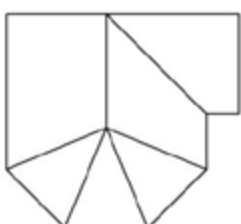

Pitch variance on either side of valley should be no more than 10° in glass and 15° in polycarbonate.

Less preferred design

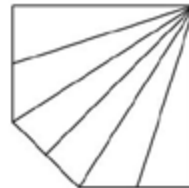

Rafters bar end caps not parallel to eaves.

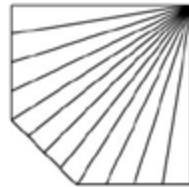

Maximum 7 rafters bars to corner.
Sealed units are weak due to long slim lengths to a point.

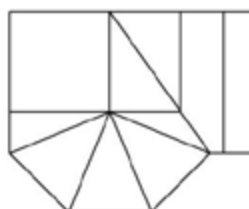

No return on valley gives poor rafter glazing at lower valley area.
No position for a tie bar.
Additional costs.

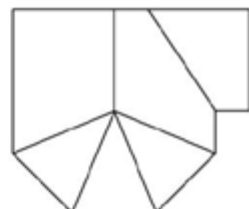

Poor glazing performance on drop valleys.
Increased time and cost with lead flashing.

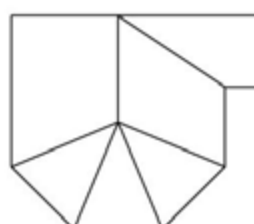

Unequal pitches on either side of valley.
It is possible to have a greater variance but performance is reduced.

BASE DETAILS

Aesthetics, costs and ease of installation need to be considered when planning a conservatory against two host walls. Shown below are the preferred designs which lend themselves to ease of manufacture, quicker installation, improved aesthetics whilst keeping costs to a minimum.

Preferred design

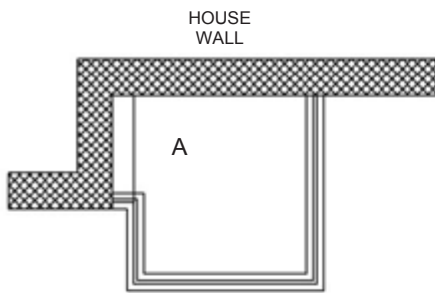

A) Return base wall under the box gutter to avoid using a raised box gutter thus reducing costs.

The panel under the box gutter gives an optimum position for the rain water pipe. Option to use a brick pier in place of a window frame/panel at this point.

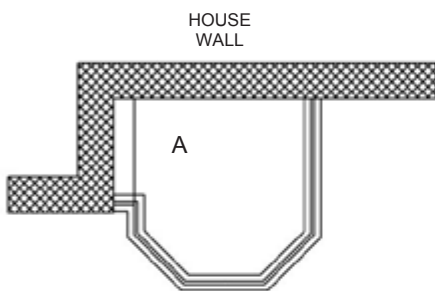

B) Raised or sloping box gutters increases costs, manufacturing and installation time.

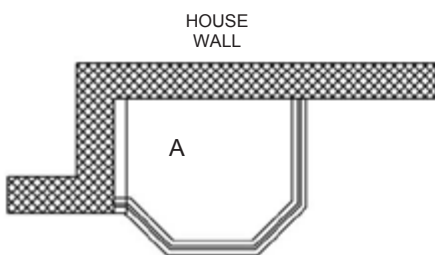

C) Positioning frame as shown creates a void at house wall, making fixing difficult.

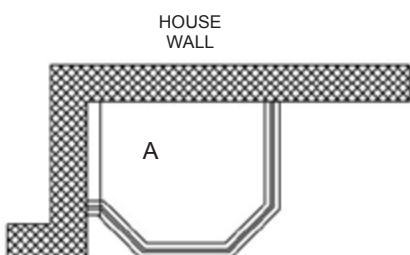

D) The overhang on the box gutter is uneven and looks unsightly. Roof facets and panels are unequal giving poor aesthetics.

Less preferred design

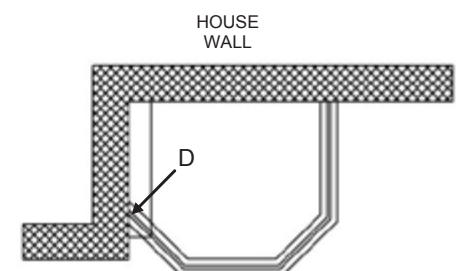
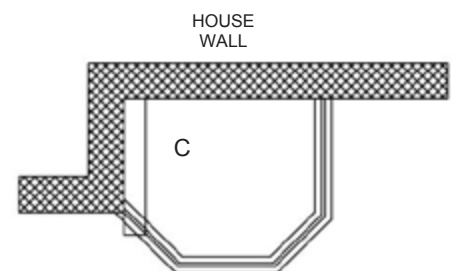
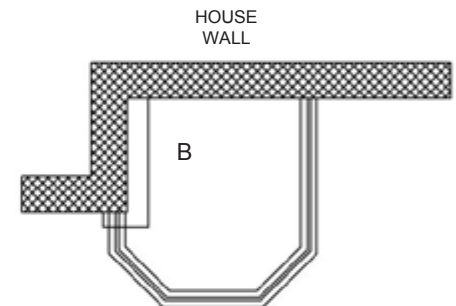
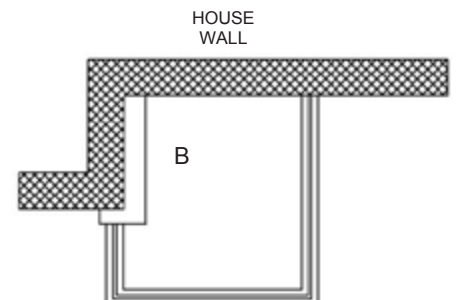

DRAINAGE OPTIONS

Additional outlets are required when roof plan area exceeds 33m² based on 25° roof pitch. If the existing house roof is also to drain into the box gutter, this area must also be added to the total.

Transport limitations prevent continuous box gutter lengths of over 7m.

The box gutter would need splitting into two parts. These can be joined using an inline sealing pack or the split ends can be capped off and the water drain away from the split.

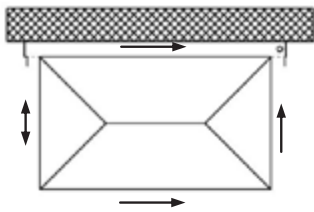

Standard box gutter

Welded aluminium outlet on one end of box gutter and a welded adapter on the other. Plastic guttering drains into the box gutter.

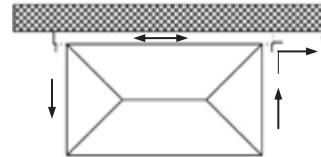

Box gutter 3-way adapter

Plastic gutter runs into welded 3-Way Adapter on right hand side of box gutter.

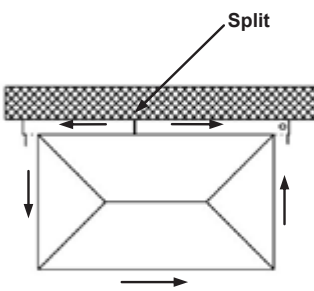

Split box gutters

As above, but with split in box gutter. Box gutter is split at 7m in length to allow for transportation.

Transportation Size Restrictions:
7m in length x 2.3m in height.

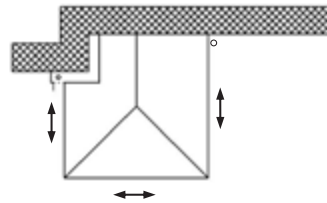

Built up box gutter

A box gutter outlet can be at this point or alternatively drain into the outlet in the plastic gutter.

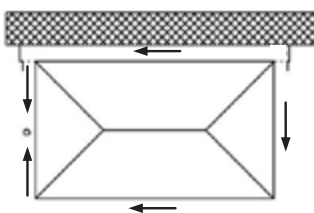

Plastic running outlet

Welded adapters on both ends of box gutter. Water drains into plastic guttering and into running outlets.

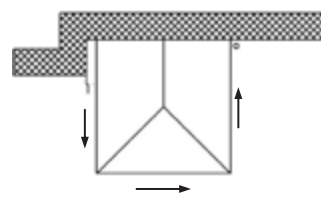

Inline box gutter

Box gutter inline adapter allows water to run into plastic gutter with outlet positioned on other facet.

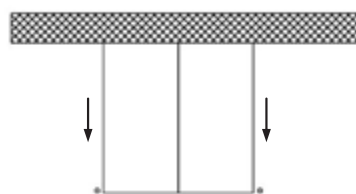

Gable roofs

Generally gable ended roofs require an outlet on either side, however gutter can be fitted around the front of the conservatory if a Gable eaves beam is run across the front of the gable.

ROOF SIZE WITH END FRAMES

Generally, roofs are dimensioned on the survey to the internal window frame size. However, care needs to be taken on Lean-to roofs, combination and gable roofs where a common error is to forget that the roof carries over the end window frames by the profile thickness. Some favour an additional 5 or 10mm overhang to provide an improved seal.

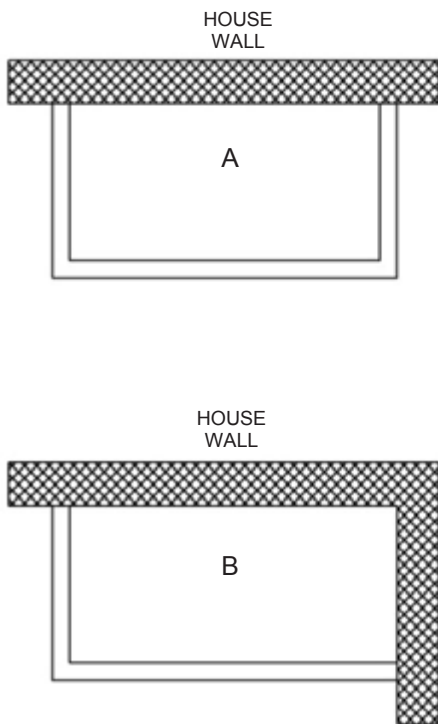

Internal width is measured between

- A) Frames on both ends. Add profile widths of both frames to gain overall roof width.
- B) Frame on one side only, add profile widths of one frame to gain overall roof width.
- C) No frames, roof between two walls. No profile width to be added so internal width will be overall roof width.

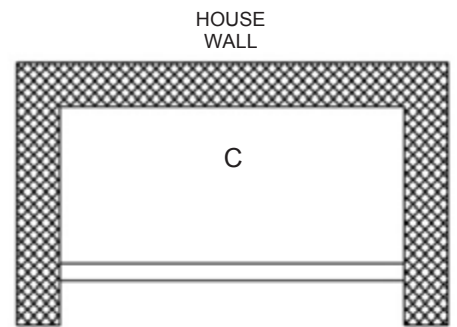

1

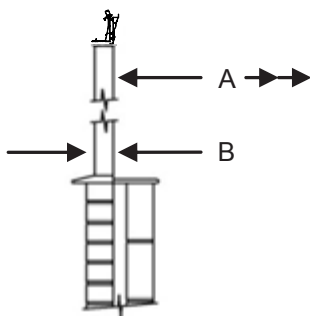

Profile dimensions

- A) Internal width to this point.
- B) Profile thickness/width.

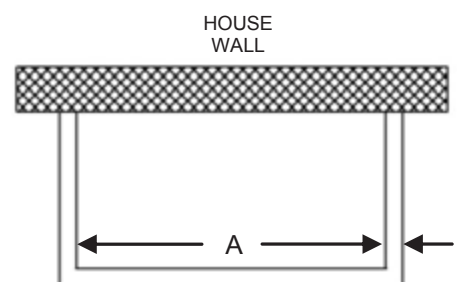

2

Same principles apply to combination and gable roof styles.

3

BASE CALCULATIONS

The following calculation methods give facet lengths assuming standard and common facet angles and pitches.

To calculate combination roofs the same principles are applied by calculating the separate sizes then joining them together.

Standard 3 facet Victorian 135° angles

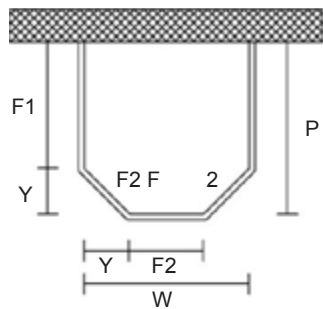

$$F2 = W / 2.4142$$

$$Y = F2 / 1.4142$$

$$F1 = P - Y$$

Example: 3m x 3m
 $1243 = 3000 / 2.4142$
 $879 = 1243 / 1.4142$
 $2121 = 3000 - 879$

Wide front 3 facet Victorian 135° angles

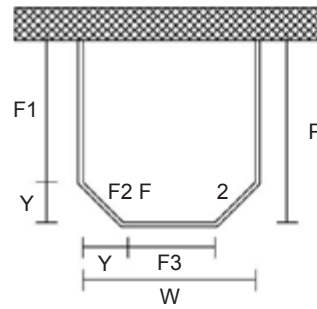

$$Y = (W - F3) / 2$$

$$F2 = Y \times 1.4142$$

$$F1 = P - Y$$

Example: 3m x 3m
 $750 = (3000 - 1500) / 2$
 $530 = 750 / 1.4142$
 $2250 = 3000 - 750$

Standard 5 facet Victorian 150° angles

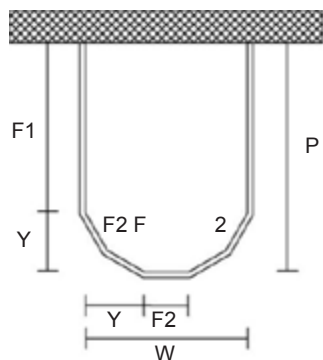

$$F2 = W / 3.733$$

$$Y = F2 / 2.734$$

$$F1 = P - Y$$

Example: 3m x 3m
 $804 = 3000 / 3.733$
 $1098 = 3000 / 2.734$
 $1921 = 3000 - 1079$

Wide front 5 facet Victorian 150° angles

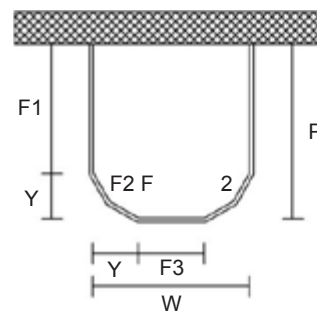

$$Y = (W - F3) / 2$$

$$F2 = Y \times 0.7325$$

$$F1 = P - Y$$

Example: 3m x 3m
 $750 = (3000 - 1500) / 2$
 $549 = 750 \times 0.7325$
 $2250 = 3000 - 750$

Two facet Victorian end 150° angles

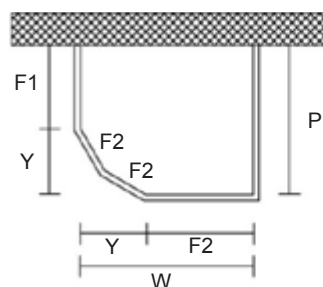

$$Y = W - F3$$

$$F2 = Y \times 0.7325$$

$$F1 = P - Y$$

Example: 4m x 3m
 $1500 = 4000 - 2500$
 $1099 = 1500 \times 0.7325$
 $1500 = 3000 - 1500$

One facet Victorian end 135° angles

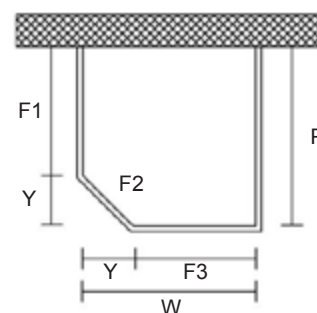

$$Y = W - F3$$

$$F2 = Y / 1.4142$$

$$F1 = P - Y$$

Example: 4m x 3m
 $1500 = 4000 - 2500$
 $1099 = 1500 / 1.4142$
 $1500 = 3000 - 1500$

STRING LINES

The use of string lines is paramount when constructing the foundations, the walls and during installation. When used from both corners of the proposed site this will confirm the first 'P' projection facets are 90° degrees from the existing property and the other facets are located correctly.

A basic knowledge of trigonometry will allow you to calculate these dimensions however software packages are readily available.

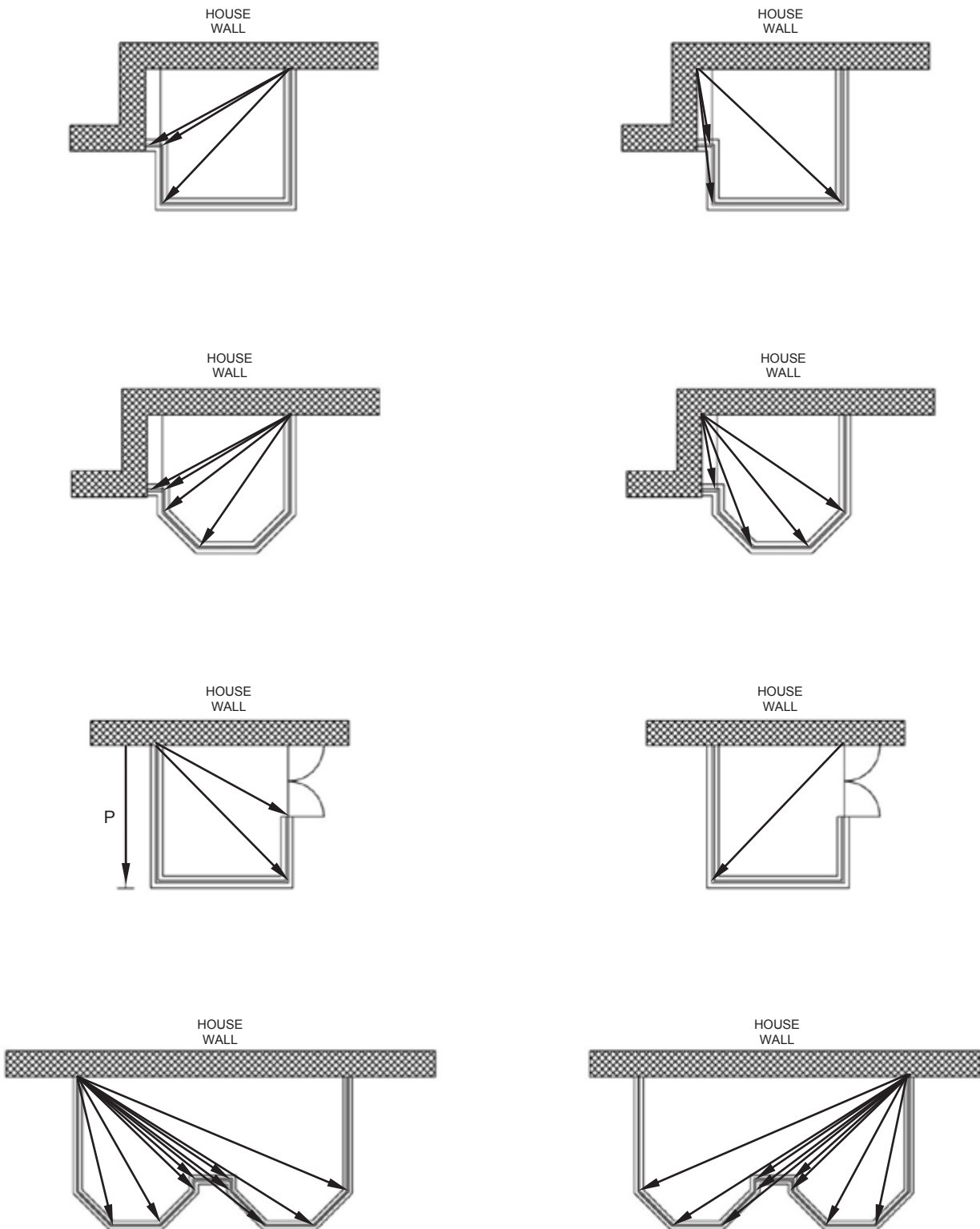

CALCULATING RIDGE LENGTHS

Use this section in conjunction with the design guide sections to obtain the most cost effective and aesthetically pleasing solution. All calculations shown are to obtain equal pitches to all roof sections.

Equal pitch to all roof sections

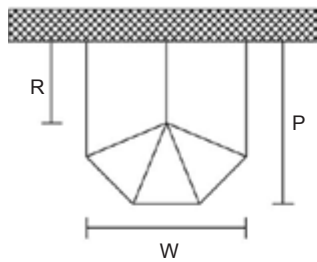

$$R = P - \frac{1}{2} W$$

Example: 4m x 3m
 $2500 = 4000 - 1500$

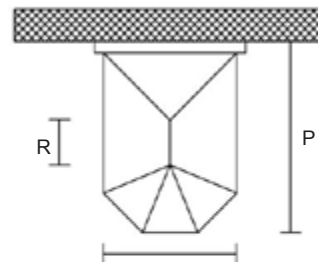

$$R = P - W - 227 \text{ (box gutter)}$$

Example: 4.5m x 3m
 $1273 = 4500 - 3000 - 227$

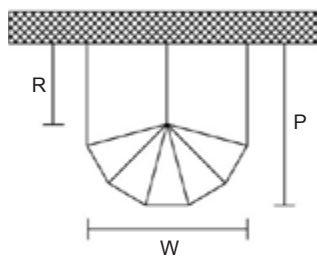

$$R = P - \frac{1}{2} W$$

Example: 4m x 3m
 $2500 = 4000 - 1500$

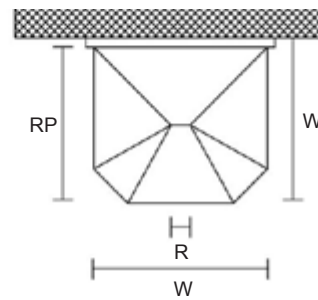

$$RP = P - 227 \text{ (box gutter)}$$

$$R = W - RP$$

Example: 3m x 4.5m
 $2773 = 3000 - 227$
 $1727 = 4500 - 2773$

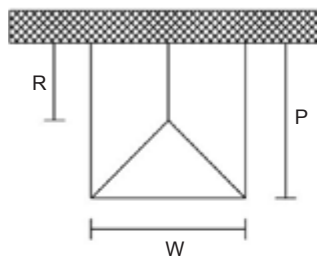

$$R = P - \frac{1}{2} W$$

Example: 4m x 3m
 $2500 = 4000 - 1500$

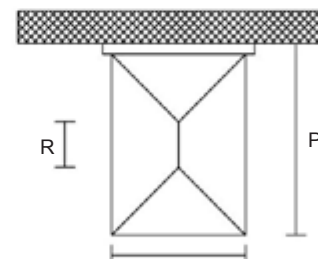

$$R = P - W - 227 \text{ (box gutter)}$$

Example: 4.5m x 3m

$$1273 = 4500 - 3000 - 227$$

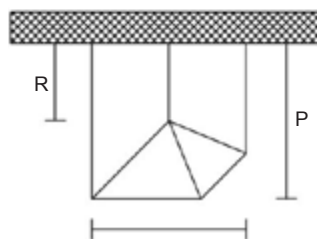

$$R = P - \frac{1}{2} W$$

Example: 4m x 3m
 $2500 = 4000 - 1500$

Ridge height calculation

RIDGE HEIGHT CALCULATION			
P= PITCH	DIMENSION A	E= EAVES HEIGHT	DIMENSION B
15	154	109	44
20	148	109	48
25	142	109	56
30	136	110	61
35	130	110	71
40	124	110	81

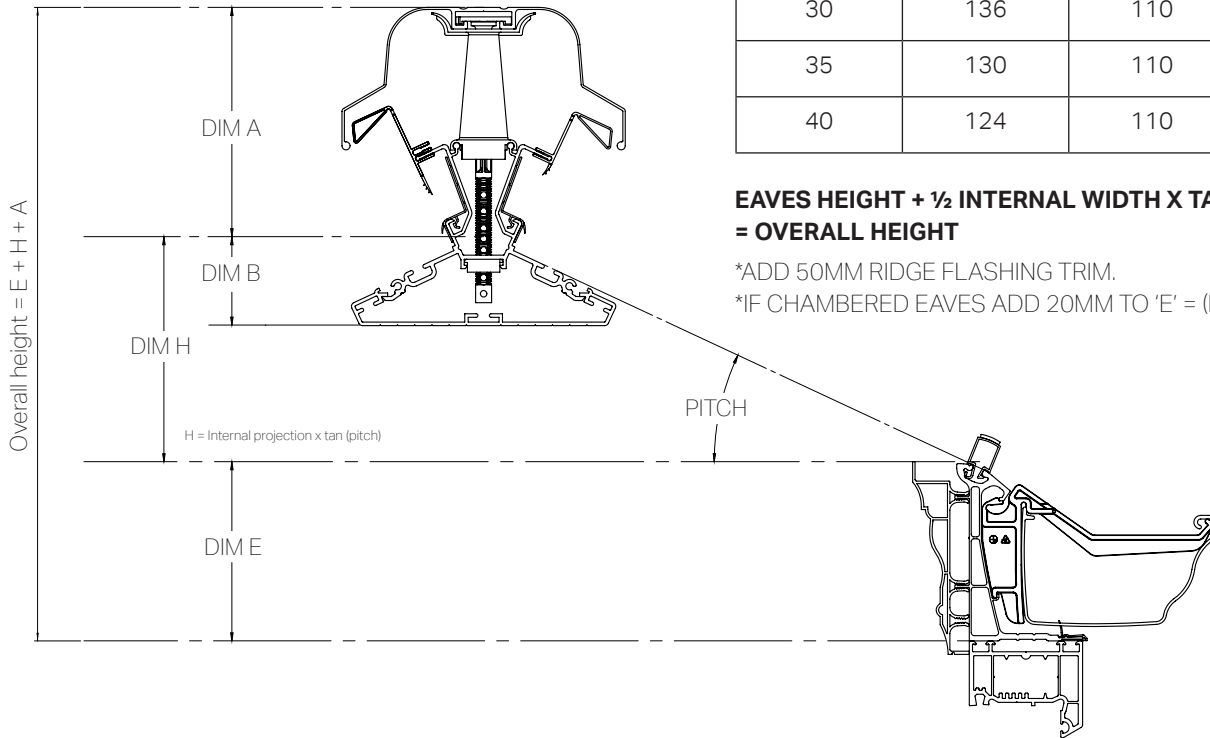

EAVES HEIGHT + ½ INTERNAL WIDTH X TAN P + DIM A = OVERALL HEIGHT

*ADD 50MM RIDGE FLASHING TRIM.

*IF CHAMBERED EAVES ADD 20MM TO 'E' = (EAVES HEIGHT)

Half ridge height calculation

HALF RIDGE HEIGHT CALCULATION		
P=PITCH	DIMENSION A	DIMENSION B
5°	219	32
10°	209	41
15°	200	51
20°	190	60
25°	181	69
30°	171	79

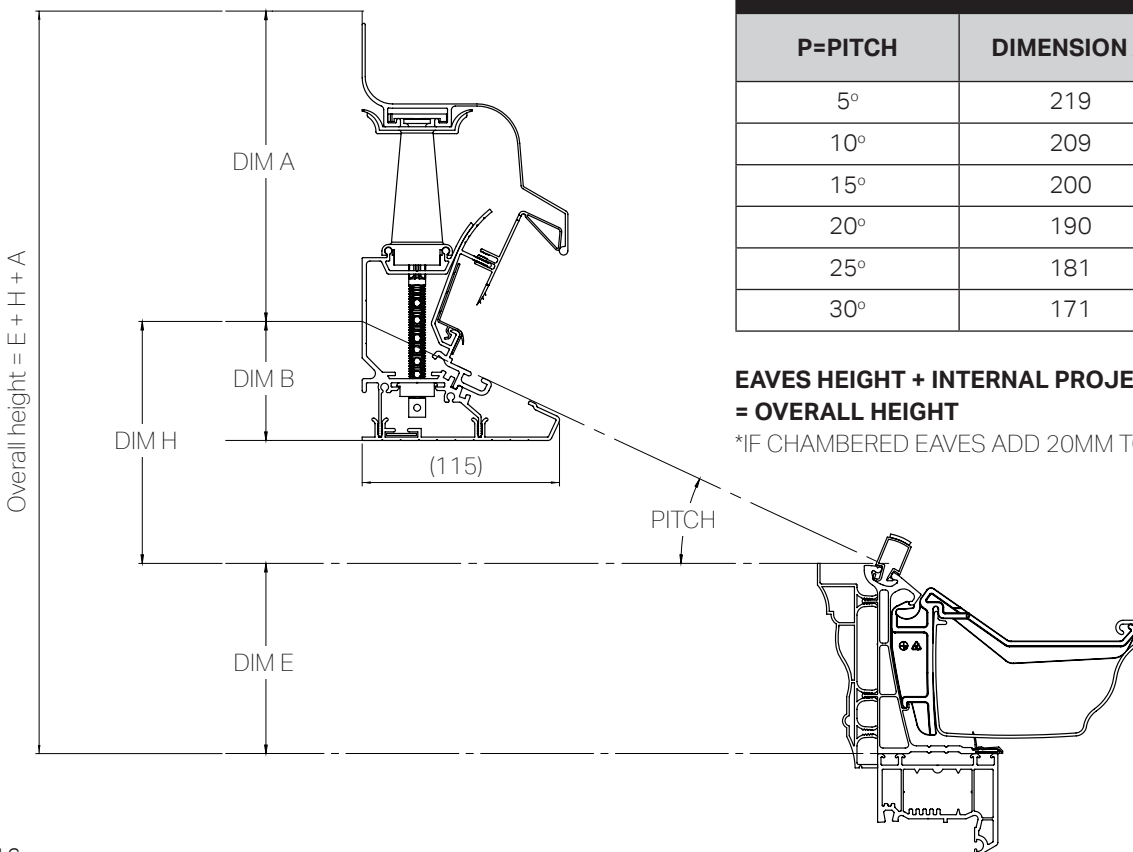

EAVES HEIGHT + INTERNAL PROJECTION X TAN P + DIM A = OVERALL HEIGHT

*IF CHAMBERED EAVES ADD 20MM TO 'E' = (EAVES HEIGHT)

Low pitch eaves and lean-to wallplate

RIDGE HEIGHT CALCULATION			
P= PITCH	DIMENSION A	E= EAVES HEIGHT	DIMENSION B
2.5	149	70	22
20	147	70	24
7.5	145	70	26
10	143	70	28
12.5	141	70	30
15	139	70	32

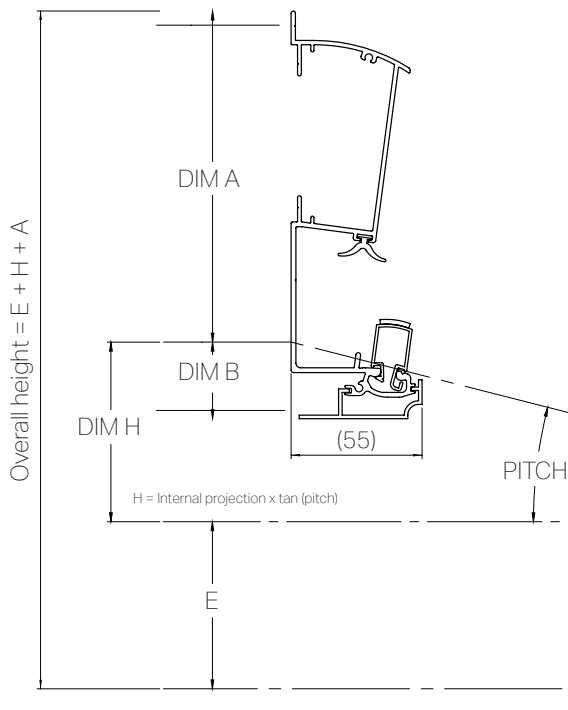

EAVES HEIGHT + ½ INTERNAL WIDTH X TAN P + DIM A = OVERALL HEIGHT

*ADD 50MM RIDGE FLASHING TRIM

Lean-to wallplate

RIDGE HEIGHT CALCULATION			
P= PITCH	DIMENSION A	E= EAVES HEIGHT	DIMENSION B
2.5	149	109	22
20	147	109	24
7.5	145	109	26
10	143	109	28
12.5	141	109	30
15	139	109	32

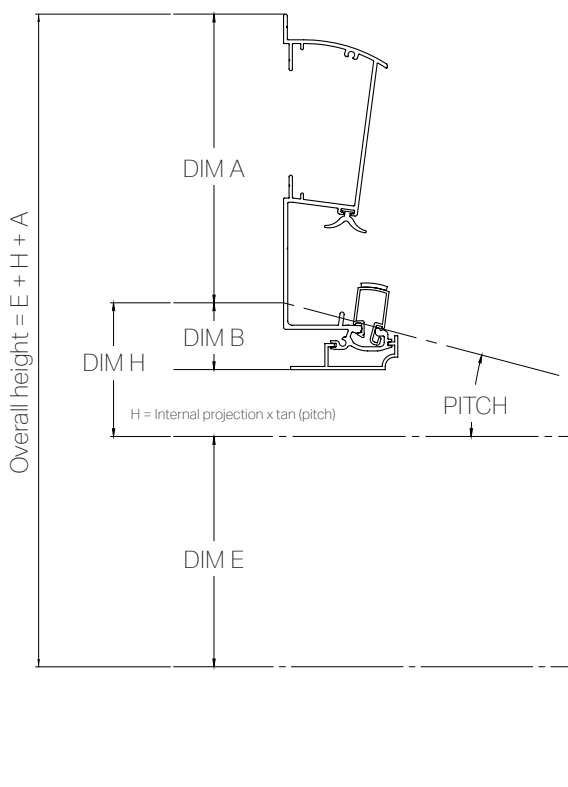







EAVES HEIGHT + INTERNAL PROJECTION X TAN P + DIM A = OVERALL HEIGHT

*IF CHAMBERED EAVES ADD 20MM TO 'E' = (EAVES HEIGHT)

GLAZING RECOMMENDATIONS

Basic roof parameters are shown below as a guide to assist during survey. Please refer to the glazing bar design guide for clarity on maximum glazing bar centres in relation to site location and glazing material used.

Roof style		Pitch range	Glazing material	Glazing thickness - mm		
	LPR Lean-to	2.5° - 15°	Polycarbonate	-	-	35
		5° - 15°	Glass	24	-	-
	Standard lean-to	5° - 40°	Polycarbonate or glass	24	25	35
	3 Bay Victorian	15 - 37.5°	Polycarbonate or glass	24	25	35
	5 Bay Victorian	15° - 37.5°	Polycarbonate or glass	24	25	35
	Edwardian	20° - 30°	Polycarbonate or glass	24	25	35
	Gable	15° - 40°	Polycarbonate or glass	24	25	35
	Valley	5° - 40° (up to 15° pitch difference)	Polycarbonate or glass	24	25	35

GLASS SIZES

There are manufacturing size limitations when it comes to glass. If these limitations are exceeded the glazing panel will need to be split into more manageable pieces and joined using our aluminium glass joiner and sealed using silicone.

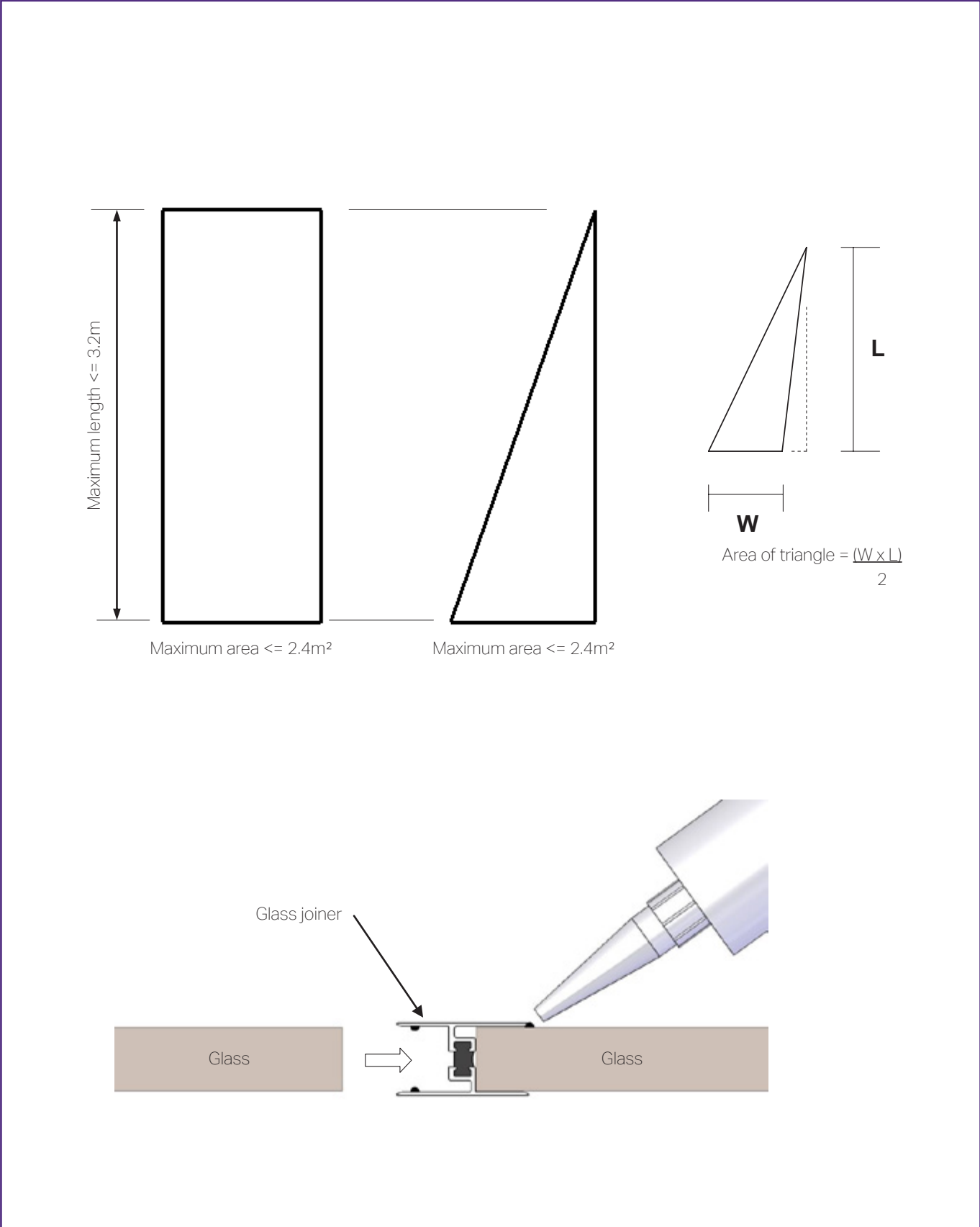

COMBINATION ROOFS

Use this section in conjunction with the design guide section. All combination roofs require a minimum of one 3 way tie bar across the bay of the Victorian/Edwardian.

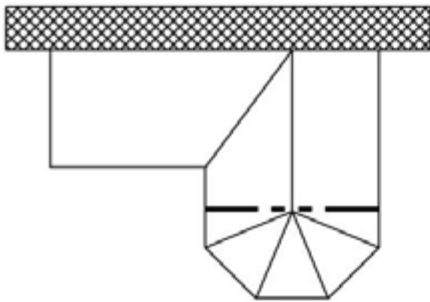

A) During the design consideration to the location of the tie bar, as shown. Best design allowing tie bar to be located in the optimum position.

B) Ridge length is required to be 200mm greater than the lean-to projection.

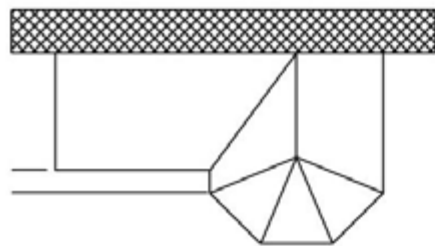
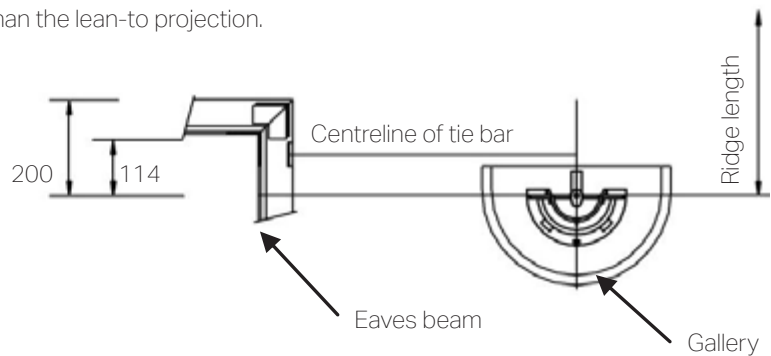

C) Return from the Victorian/Edwardian to the lean-to requires a minimum of 400mm to allow for correct glazing around the valley. However design shown does not accommodate positioning of the tie bar.

Options:

1. *Reduce lean-to projection.*
2. *Increase Victorian/Edwardian Bay projection as shown in option B.*

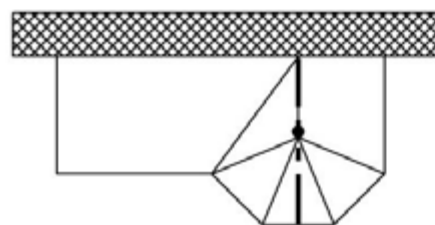

D) No return from the Victorian/Edwardian to the lean-to can be accommodated, however design shown gives reduced glazing performance at the valley section to eaves and also does not accommodate positioning of the tie bar.

Options:

1. *Use of tie bars only.*
2. *Use of structural steel or aluminium supports to replace tie bar arrangement.*
3. *Change design as shown in option B.*

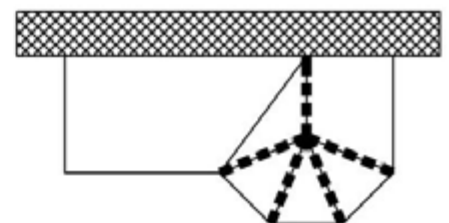

TIE BARS – COMBINATION ROOFS

Roof tie bars are specified to support the roof structure under extreme loading conditions. To be effective they should ideally be positioned perpendicular to the ridge to the inner valley corner so as to prevent the valley corner from moving. In all cases it is assumed that the structural integrity of the wall or window frames is adequate to support the dead load imposed by the roof.

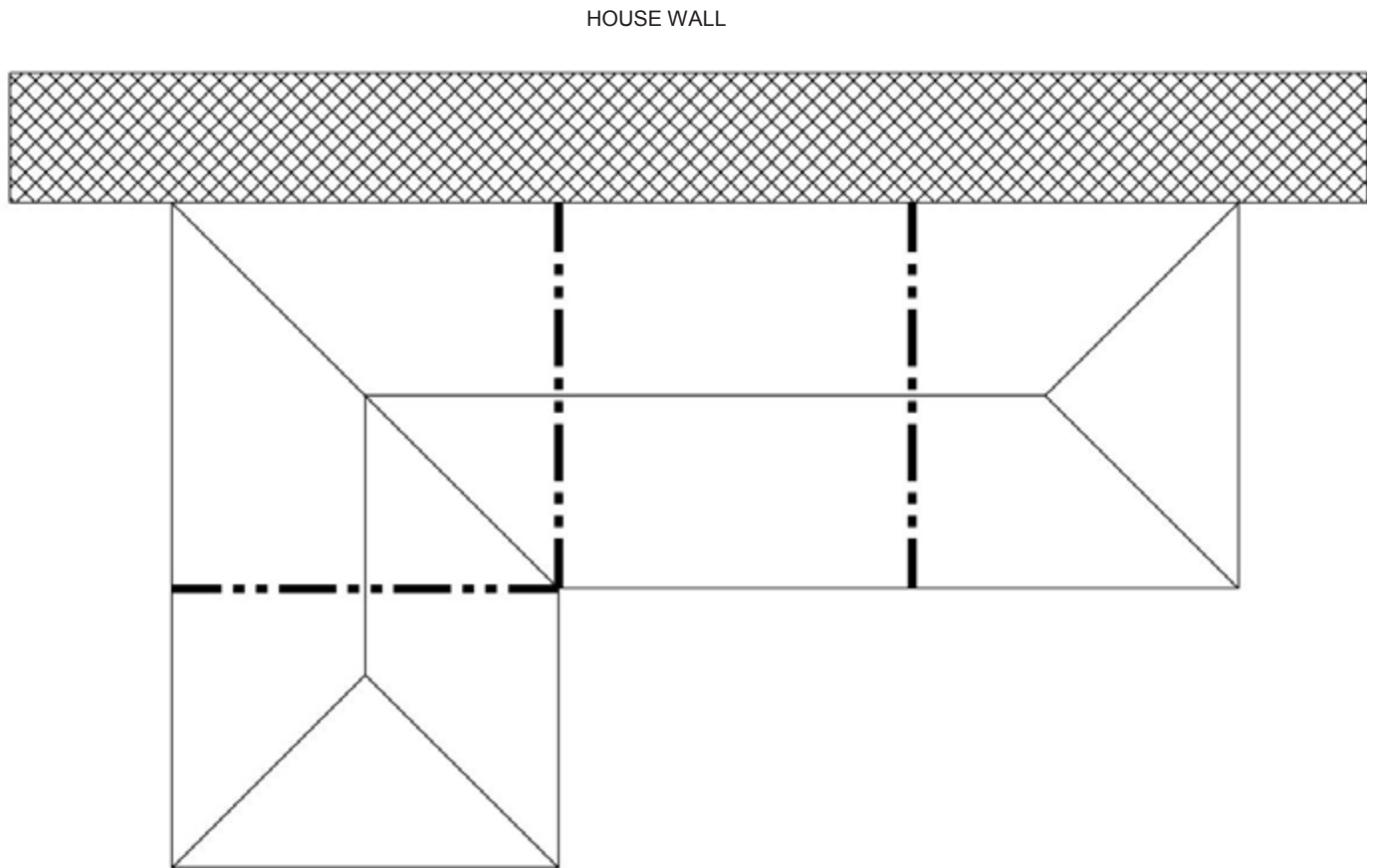

All 'P' shaped designs require a minimum of two 3 way tie bars to link the eaves beam to the lean-to portion to the side eaves beam of the Victorian/Edwardian element.

INSULATED PELMENT/CORNICE

The insulated pelment is available in internal soffit projections from 300mm to 1200mm (measured from internal frame). The product has 2 options, 'On Fascia' and 'Below Fascia' (which requires a frame add on but allows the framework and plasterboard to go under the box gutter).

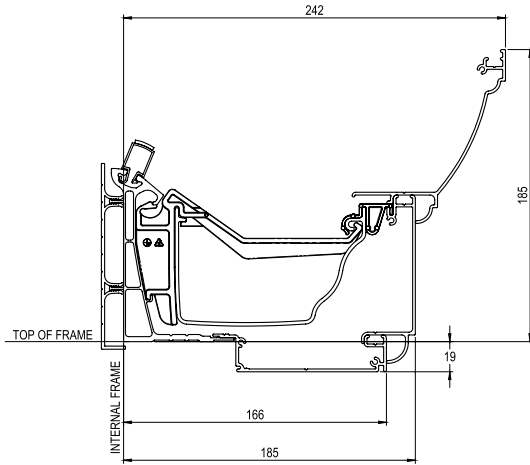

Curved cornice

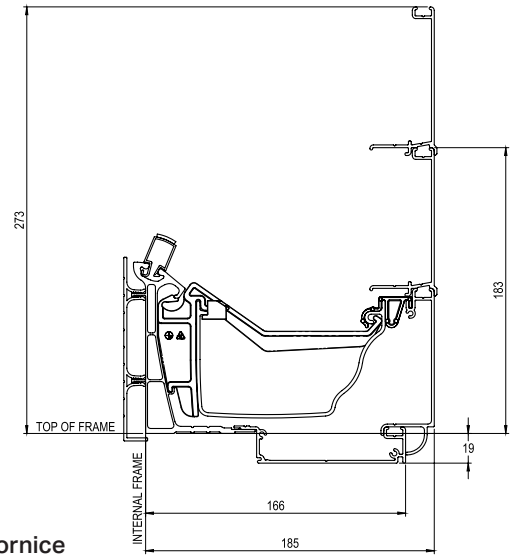

Flat fronted cornice

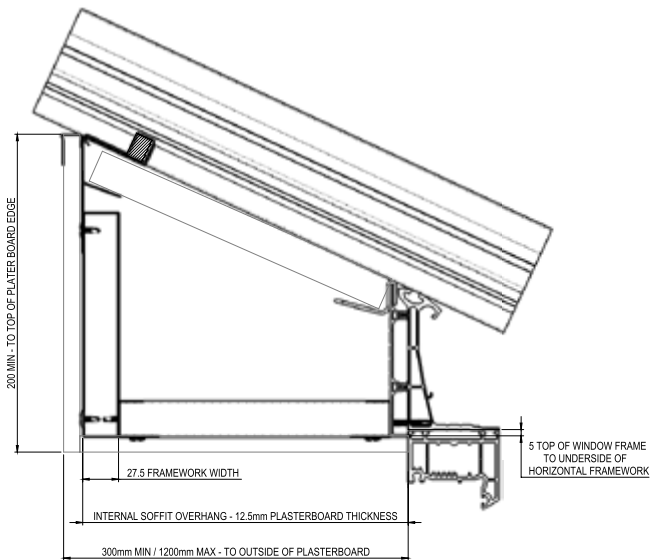

Standard eaves below fascia

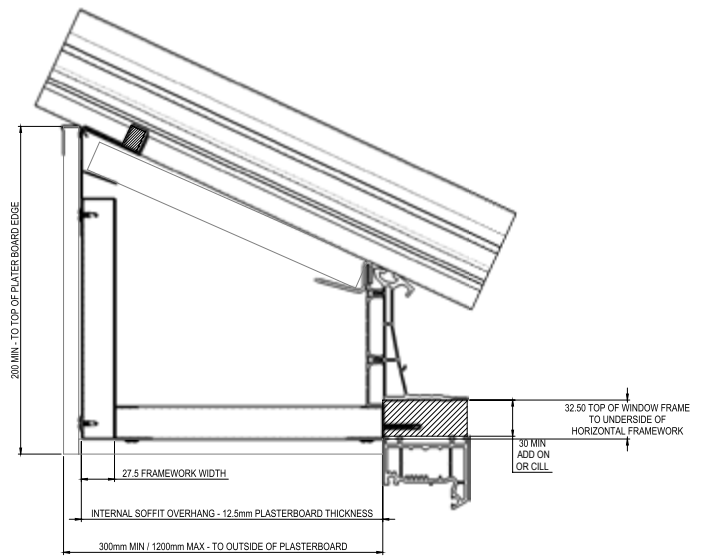

Below fascia

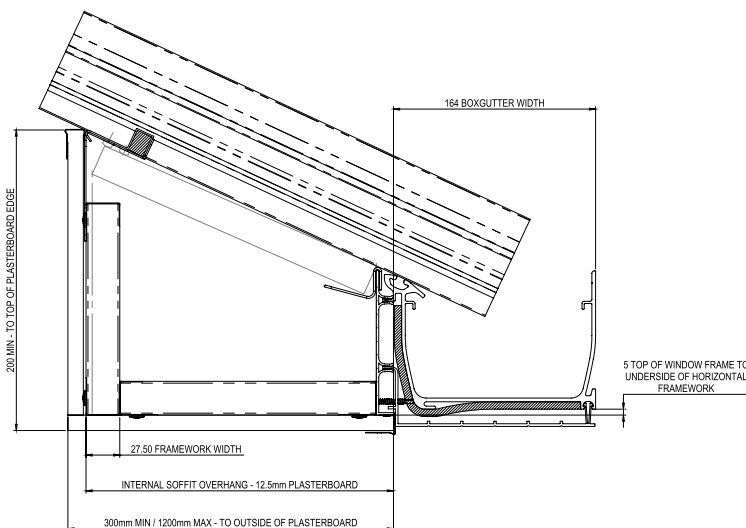

Box gutter on fascia

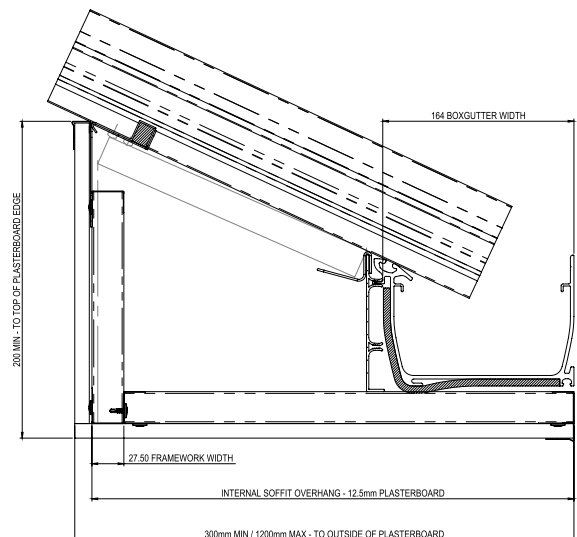

Box gutter below fascia

PATIO / BI-FOLD DOORS

Wide spanning doors have no integral strength and are very susceptible to vertical movement which can hinder operation. Additional support is required to span the opening and can be achieved using various methods.

Standard eaves beam

For shorter spans our standard box gutter eaves beam will suffice. Please refer to the tables for span capability.

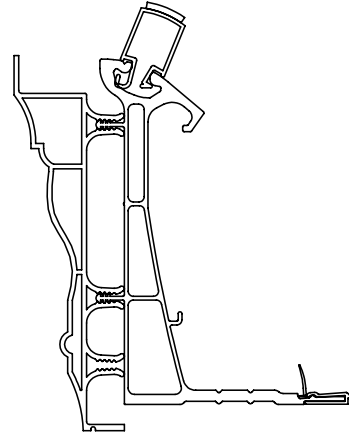

Option 1

Reinforced eaves beam

For larger spans the chambered eaves beam can accommodate a bolster section which carries the Heritage cladding. Please refer to the tables for span capability.

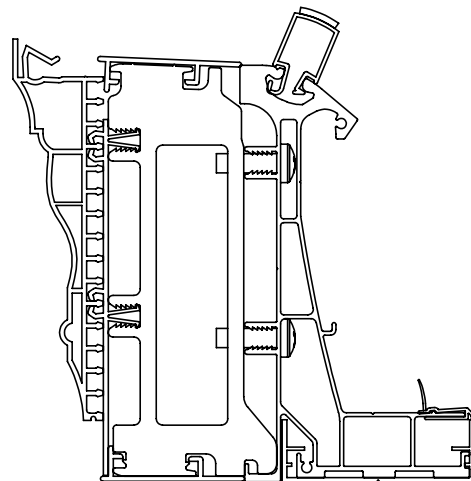

Option 2

Steel structure

If a greater span is required, a steel structure can be erected inside the conservatory behind the eaves beam. Please note, there are aesthetic compromises, increased complexity and greater cost implications with this option. Please refer to the pictures for options. Please contact Quantal for assistance if this is required.

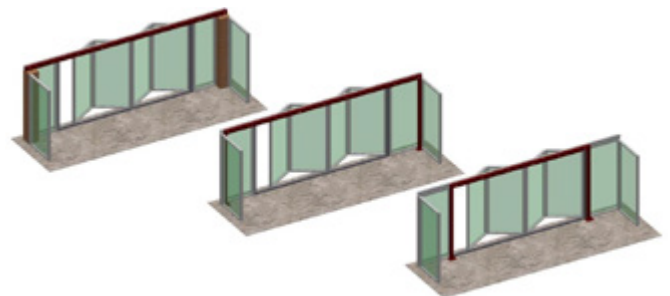

Option 3

SPAN CHARTS

- Imposed Load = 0.6 kN/m².
- Roof pitches = up to 15° for monopitch, up to 25° for duopitch and hip/gable.
- A wind load check must also be carried out on gable eaves beams over 3.90m.
- 5mm of deflection under maximum load which must be confirmed as acceptable by bi fold door supplier. This information relates to bottom rolling Bi-Fold doors only (i.e. self weight of doors not included).
- Suitable lateral and vertical support must be provided within window/wall structure at the edge of the opening by the conservatory designer / retailer to support the eaves beam.
- Quantal cannot accept responsibility for the overall stability of the conservatory unless a portal frame is supplied by Quantal.
- Beyond this guidance refer to Quantal Technical Dept.

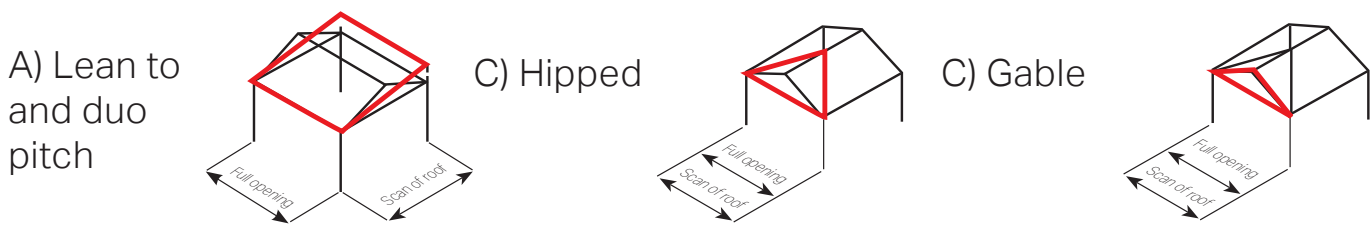

Roof span (m)	1	1.25	1.5	1.75	2	2.25	2.5	2.75	3	3.25	3.5	3.75	4	4.25	4.5	4.75	5	5.25	5.5	5.75	6
Standard eaves beam																					
Lean-to	2.92	2.77	2.65	2.55	2.47	2.40	2.34	2.29	2.24	2.20	2.16	2.12	2.09	2.05	2.03	2.00	1.97	1.95	1.93	1.91	1.89
Duo Pitch	2.91	2.76	2.64	2.54	2.46	2.39	2.33	2.28	2.23	2.19	2.15	2.11	2.08	2.05	2.02	1.99	1.96	1.94	1.92	1.90	1.88
Hipped	1.00	1.25	1.50	1.75	2.00	2.25	2.50	2.50	2.39	2.30	2.22	2.14	2.08	2.02	1.96	1.91	1.86	1.81	1.77	1.73	1.70
Chambered eaves beam																					
Lean-to	3.50	3.32	3.18	3.06	2.96	2.88	2.81	2.74	2.68	2.63	2.58	2.54	2.50	2.46	2.43	2.40	2.37	2.34	2.31	2.29	2.26
Duo Pitch	3.48	3.30	3.16	3.05	2.95	2.87	2.79	2.73	2.67	2.62	2.57	2.53	2.49	2.45	2.42	2.39	2.36	2.33	2.30	2.28	2.25
Hipped	1.00	1.25	1.50	1.75	2.00	2.25	2.50	2.75	2.87	2.76	2.66	2.57	2.49	2.42	2.35	2.29	2.23	2.18	2.13	2.08	2.04
Reinforced eaves beam																					
Lean-to	4.52	4.30	4.12	3.98	3.86	3.75	3.66	3.57	3.50	3.43	3.37	3.32	3.27	3.22	3.17	3.13	3.09	3.06	3.02	2.99	2.96
Duo Pitch	4.50	4.28	4.11	3.96	3.84	3.73	3.64	3.56	3.49	3.42	3.36	3.30	3.25	3.20	3.16	3.12	3.08	3.04	3.01	2.98	2.95
Hipped	1.00	1.25	1.50	1.75	2.00	2.25	2.50	2.75	3.00	3.25	3.47	3.36	3.25	3.16	3.07	2.99	2.92	2.85	2.78	2.72	2.67
Low pitch eaves beam																					
Lean-to	2.00	1.90	1.81	1.74	1.69	1.64	1.60	1.56	1.52	1.49	1.47	1.44	1.42	1.40	1.38	1.36	1.34	1.33	1.31	1.30	1.28
Duo Pitch	1.99	1.89	1.80	1.74	1.68	1.63	1.59	1.55	1.52	1.49	1.46	1.44	1.41	1.39	1.37	1.35	1.34	1.32	1.30	1.29	1.28
Hipped	1.00	1.25	1.50	1.75	1.99	1.88	1.79	1.70	1.63	1.57	1.51	1.46	1.41	1.37	1.33	1.30	1.26	1.23	1.21	1.18	1.15
Standard box gutter																					
Lean-to	Maximum unsupported length is 2.3m and at tiebar positions. Refer to standard boxgutter support page 26																				
Duo Pitch																					
Hipped																					
Chambered box gutter																					
Lean-to	Maximum unsupported length is 4.0m and at tiebar positions. Refer to chambered boxgutter support page 26																				
Duo Pitch																					
Hipped																					
Standard gable eaves beam																					
Gable	1.00	1.25	1.50	1.75	2.00	2.25	2.50	2.75	3.00	3.25	3.50	3.51	3.41	3.31	3.22	3.14	3.06	2.99	2.93	2.87	2.81
Reinforced standard gable eaves beam																					
Gable	1.00	1.25	1.50	1.75	2.00	2.25	2.50	2.75	3.00	3.25	3.50	3.64	3.54	3.45	3.36	3.28	3.20	3.13	3.06	3.00	2.94
Chambered gable eaves beam																					
Gable	1.00	1.25	1.50	1.75	2.00	2.25	2.50	2.75	3.00	3.25	3.50	3.75	3.69	3.58	3.49	3.40	3.32	3.24	3.17	3.11	3.04
Reinforced chambered gable eaves beam																					
Gable	1.00	1.25	1.50	1.75	2.00	2.25	2.50	2.75	3.00	3.25	3.50	3.75	4.00	4.25	4.32	4.22	4.13	4.04	3.95	3.88	3.80

BOX GUTTER SUPPORT

ALL box gutters (especially those with tie bars or joints) MUST be supported.

Quantal recommends several types of support for box gutters including brick piers. Fitting a conservatory box gutter without adequate support will lead to structural failure. Please take the correct steps BEFORE installation.

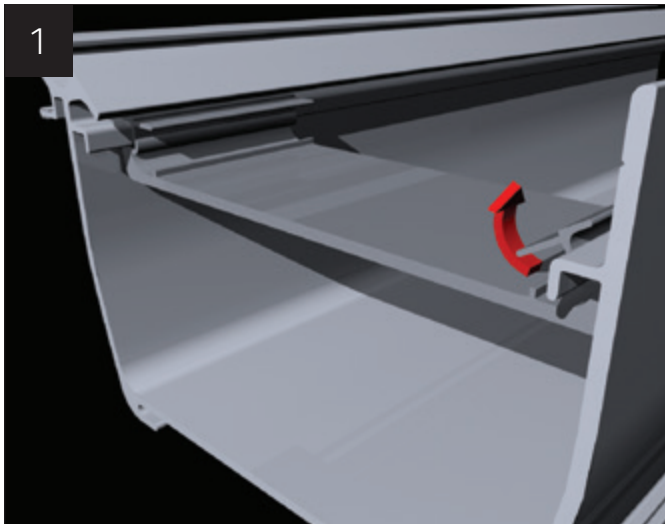

1 Box Gutter Strap

165mm box gutters

These are supplied loose and **MUST BE FITTED** – they are a structural requirement of the roof. The straps must be installed within 75mm of glazing bar centres (when measured from centre of the strap to the centre of the bar). To install these straps, simply ‘nip up’ as shown.

265mm/special box gutters

Straps are factory welded into position.

2 Box Gutter Hanger

165mm box gutters

If these have been specified by your company at the time of order they are supplied loose and must be fitted.

The structural requirement for the hanging brackets are 2 x hanging brackets (sat side by side) at a maximum span of 2300mm unless the roof has a tie bar or joint on the boxgutter which should then be positioned in the same area.

Drill through the head of the hanger into the centre of the masonry, avoiding the mortar joint if possible. Use a masonry anchor suitable for the substrate. Lead flashing should be dressed down over the hanger, and snipped around the sloped leg. To attach it to the box gutter, simply ‘nip up’ as shown.

265mm box gutters

Hanger not available.



3 Gallows Bracket

These are available for 165mm / 265mm box gutters.

To install, notch out the insulation to ensure metal to metal contact between the extruded box gutter and gallows bracket. Offer up the gallows bracket and mark it ready to drill – always try to line up with the centre of a brick rather than a mortar joint. Drill the gallows bracket (the positions should be similar to the ones shown). Three masonry anchors should be used that are appropriate to the substrate.

Finally, notch out the undercladding, offer it into position and clip in.

Maximum centres for standard box gutter are 2300mm and for chambered are 4000mm. If the roof has a tie bar installed or a joint within the box gutter, then a gallows bracket should be installed directly underneath it.

EAVES AND BOX GUTTERS

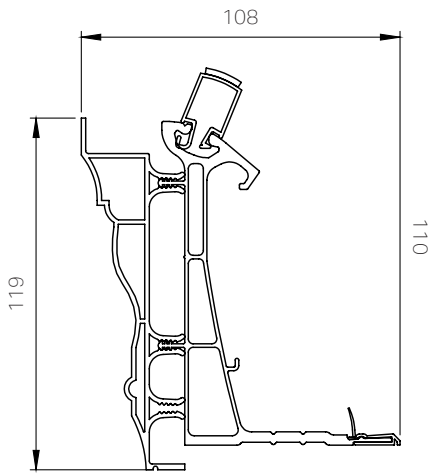

Standard eaves beam

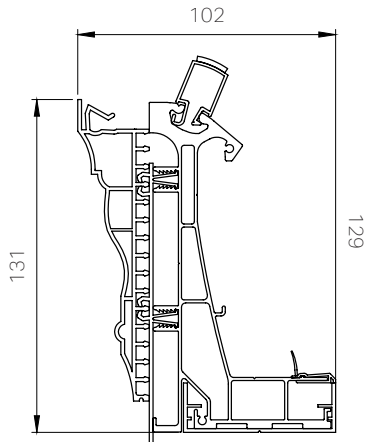

Chambered eaves beam

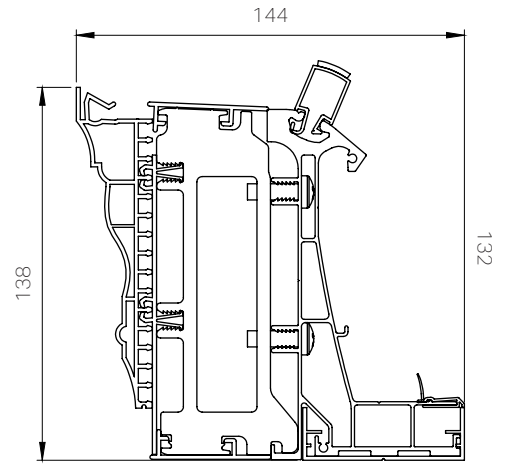

Reinforced eaves beam

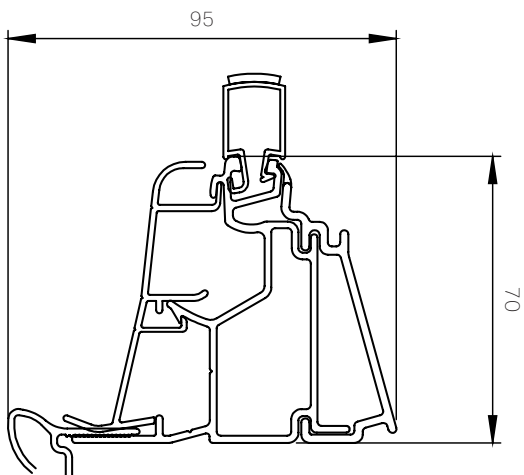

Low pitch eaves beam

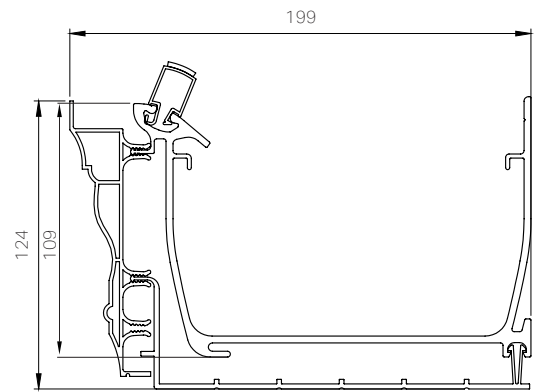

Standard box gutter

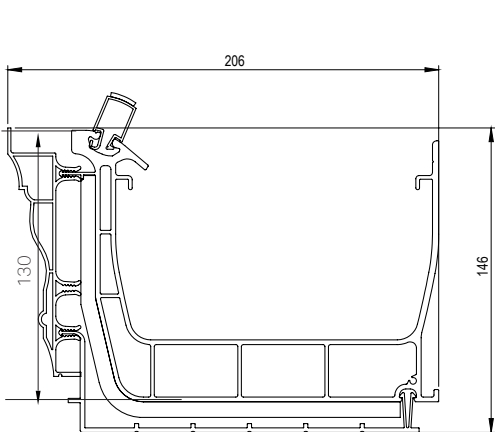

Chambered box gutter

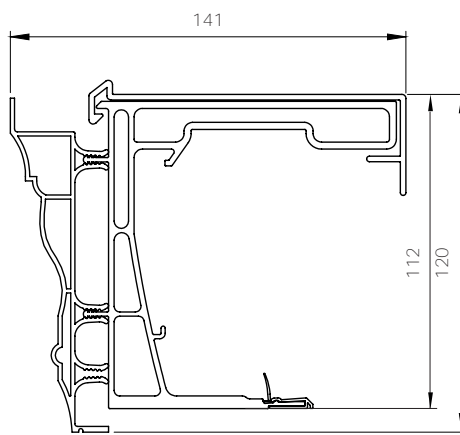

Standard gable eaves beam

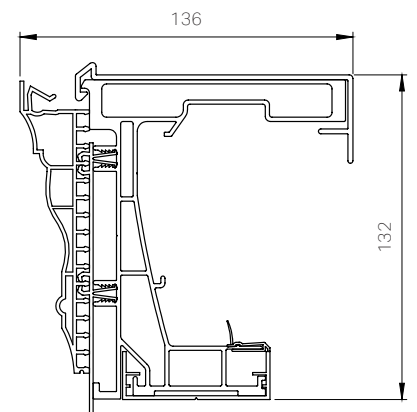

Chambered gable eaves beam

165MM ADAPTORS AND GUTTERING

LEFT HAND

BGAA001L/1(B)(D)(K)

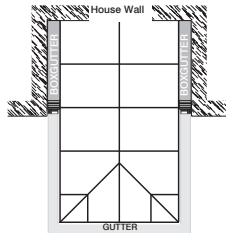
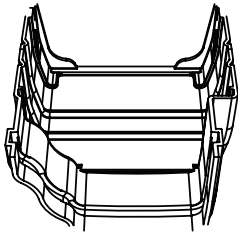

BGAA002L/1(B)(D)(K)

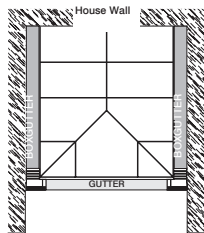
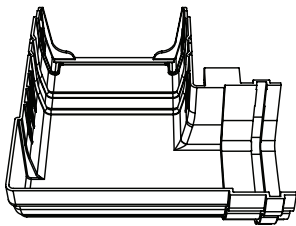

BGAA003L/1(B)(D)(K)

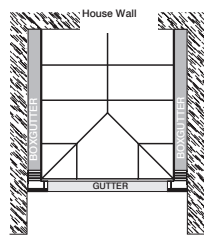
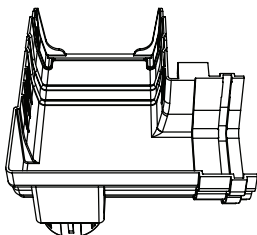

BGAA004L/1(B)(D)(K)

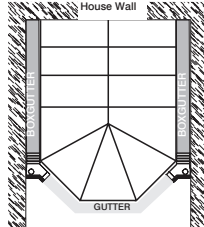
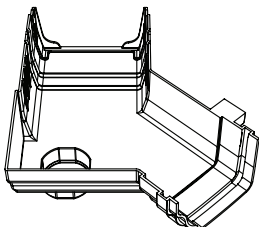

BGAA005L/1(B)(D)(K)

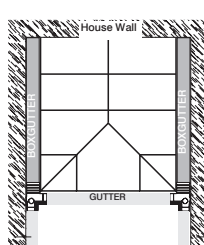
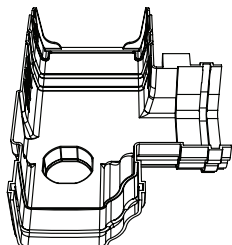

BGAA007L/1(B)(D)(K)

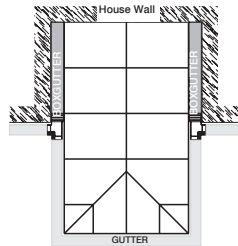
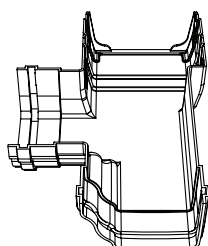

RIGHT HAND

BGAA001R/1(B)(D)(K)

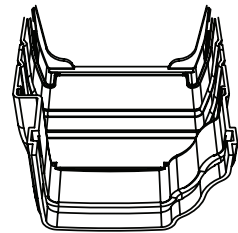

BGAA002R/1(B)(D)(K)

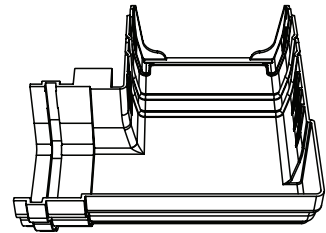

BGAA003R/1(B)(D)(K)

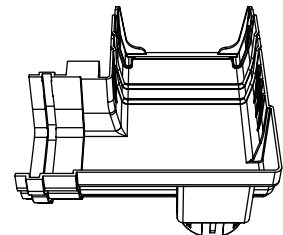

BGAA005R/1(B)(D)(K)

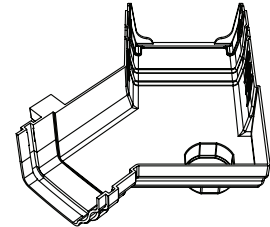

BGAA001R/1(B)(D)(K)

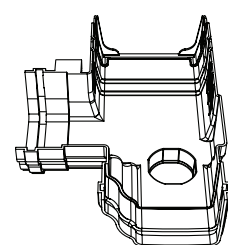

BGAA007R/1(B)(D)(K)

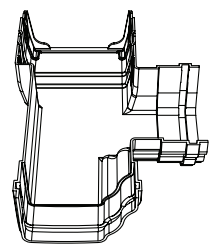

LEFT HAND

BGAA261L/1

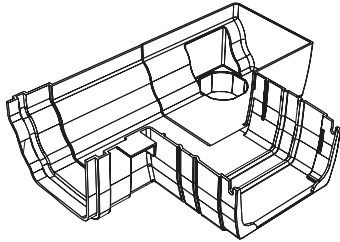

RIGHT HAND

BGAA261R/1

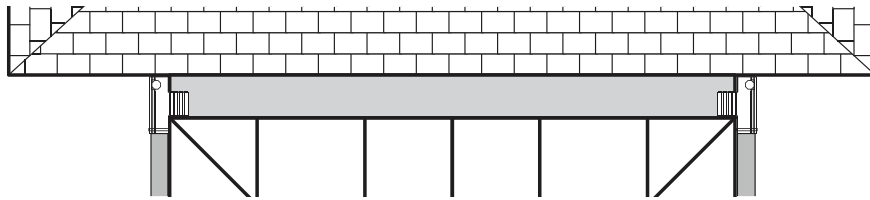
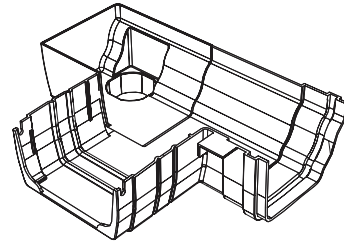

BGAA262L/1

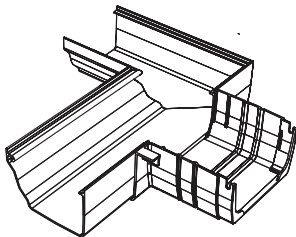

BGAA262R/1

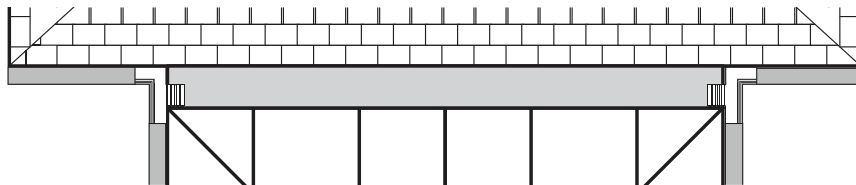
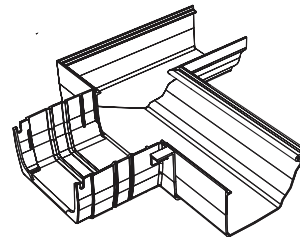

BGAA263L/1

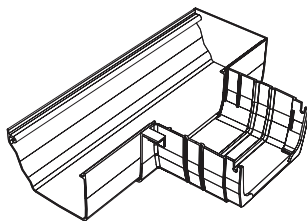

BGAA263R/1

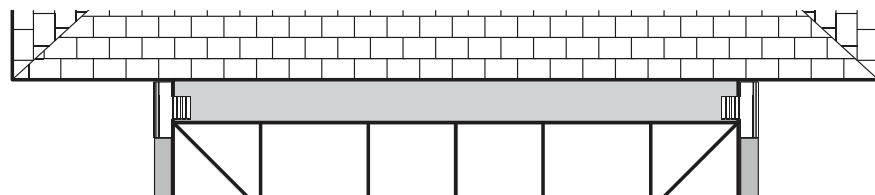
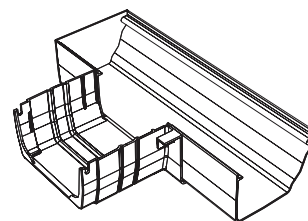

**REMEMBER
MARLEY
CLASSIC
GUTTER IS
'HANDED'**

VENTILATION

Ventilation within conservatories is paramount. During the winter months a controlled environment is required to minimise humidity and prevent condensation. During the summer months a build up of heat can render the conservatory unusable, so some method of temperature/humidity control becomes essential. A north facing conservatory will require openings of a minimum of 15% of the floor area and a south facing conservatory 25%.

Natural ventilation through roof vents is the most cost effective and traditional form.

Roof vents

Roof vents are designed to allow the heat within the conservatory to escape.

A) The vent performance is enhanced if used in conjunction with an internal paddle fan fitted to the roof ridge.

B) The top of the vent should be positioned 200mm from the top of a rectangular panel. This allows the roof vent lid to be removed from inside of the conservatory and allow access for cleaning. Minimum lower panel size of 80mm (including stepper).

There are various opening mechanism options available;

1. Manual opening via a spindle with a long Pole.
2. Teleflex which operates with conduit running from the vent to a handle mounted on the wall.
3. Electric, with options of a wall mounted switch through to a fully automated system controlled by rain, temperature and humidity sensors.

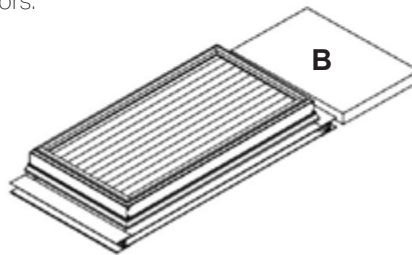

Vent Sizes: **Width**

Min: 500mm

Max: 1000mm

Vent Sizes: **Depth**

Min: 500mm

Max: 1000 (Glass), 1200 (poly)

Recommended: 700mm

Max opening: 350mm

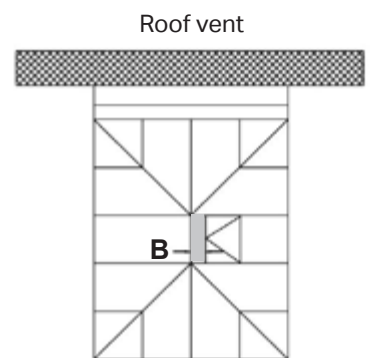

1

Ventilated glazing support

Ventilated glazing supports can be specified at various positions around the eaves beam (between bars) on the roof. These 'trickle' vents allow the homeowner to control this ventilation (open or closed).

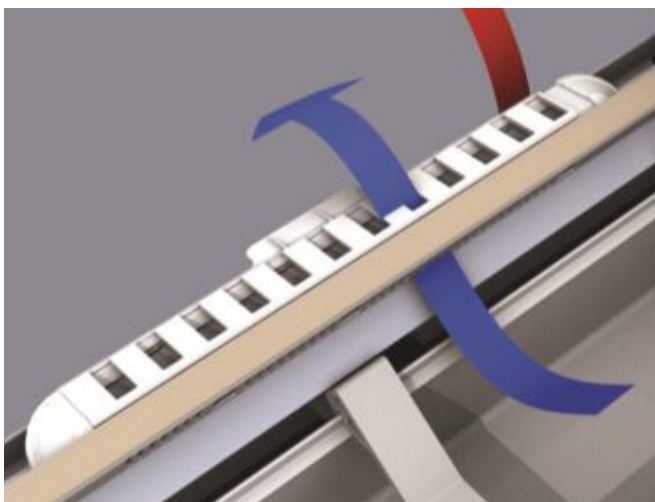

2

PORTAL FRAMES

In some instances a steel portal frame is required to support the conservatory roof or supporting walls. This could be due to the size, shape, position or site condition of the conservatory structure. The portal is positioned inside the conservatory structure so it can push or rest upon the portal. The conservatories are individually reviewed and assessed by Quantal Engineers.

The presence of a portal frame will require additional groundwork/site preparation in order to adequately provide support for the portal frame.

Note.

The Steel Portal is made from Steel Rectangular Hollow Section S275 material.

It will be split into manageable pieces and bolted together on site. Please note, a relatively small portal structure could easily weigh in excess of 200 Kg.

There are a range of finishes which can be specified such as Red Oxide, Galvanise or Powder Coat depending on site requirements.

The Steel Portal is spaced off the Conservatory Structure by 5mm to allow for site variation/adjustment and to aid in the prevention of thermal transfer. Spacer material not supplied.

The portal must be bolted to a suitable conservatory foundation as shown below.

If the Portal is to be bolted to a vertical wall, a 400 x 400mm (min) load bearing concrete pad should be specified in the wall cavity.

The foundation size and depth is site specific and would need to be assessed by a suitably qualified Geotechnical Engineer.

This information is for guidance only. Individual installations may have different requirements.

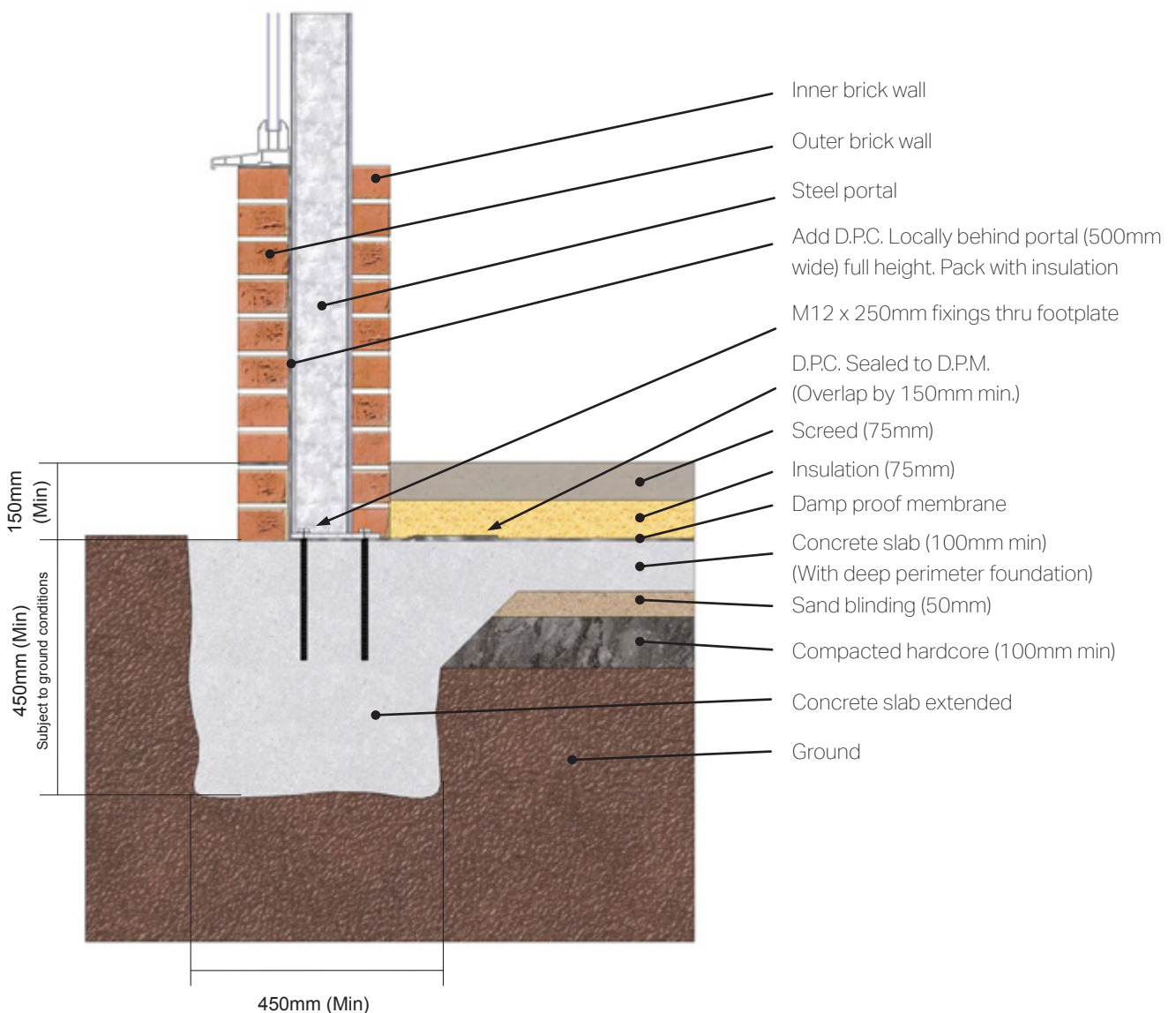

www.quantal.co.uk

Hotline: 01200 414618

Email: info@quantal.co.uk

Job No.: 4011 10/18 QSURVEYER

It is Quantal's policy to continually seek to improve its products, processes and services, and we reserve the right to change specifications without prior notice. Ultraframe is a trading name of Ultraframe (UK) Limited.

QUANTAL