

Ultrarroof Box Gutter Installation

The complete guide to installing box gutter onto an Ultrarroof.

Used in conjunction with main installation guide Version 1 January 2019.

PLEASE READ BEFORE FITTING

BOX GUTTER PRE INSTALLATION INFORMATION

Recommended tools - Refer to main Ultrarroof installation guide page 3.

Box Beam Support Requirements when Adjacent to a 265 Box Gutter

- Each length of box beam adjacent to a 265 box gutter requires support using methods 1 or 2 or a combination of methods for each length.
- Connections at corners of box beams do not provide adequate structural support for adjacent beams, each beam must be supported as an individual element.

Method 1: Using Masonry or Posts

Box Beam Unsupported Span	Support Requirements
>= 4000mm	Masonry, super insulated columns or windposts at both ends of the box beam, supporting the full width of the box beam

Method 2: Using Gallows Brackets

Box Beam Unsupported Span	Support Requirements
>= 3200mm	1 Structural gallows bracket positioned centrally where the box beam is supported at both ends by frames
>= 6400mm	2 Structural gallows brackets with a maximum cantilever of 1200mm from each end & a span not exceeding 4000mm between the gallows brackets
<= 6401mm	2 Structural gallows brackets with a maximum cantilever of 1200mm from each end plus a third gallows bracket between where the maximum unsupported span does not exceed 4000mm

Gallows Bracket Options - Currently 2 types of structural gallows brackets

Type 1 - NRSB001MW	Suitable for use where the box gutter is attached directly to a wall or when attached to a fascia the soffit width does not exceed 100mm
Type 2 - Custom Bracket	Suitable for use where the box gutter is attached to a fascia where the soffit width does not exceed 550mm

Post Options

Super insulated columns	Positioned under the end of the box beam, where unsupported spans do not exceed 4000mm
Steel or Aluminium Posts	With plates welded to both ends

(>= upto or equal to, <= less than or equal to)

INSTALLATION - BOX GUTTER - 265MM / TAPERED BOX GUTTER (PAGE 7)

Fitting of box beam support shelves. (Refer to box gutter layout examples on following pages)

USE THE KEY BELOW FOR FITTING SEQUENCE.

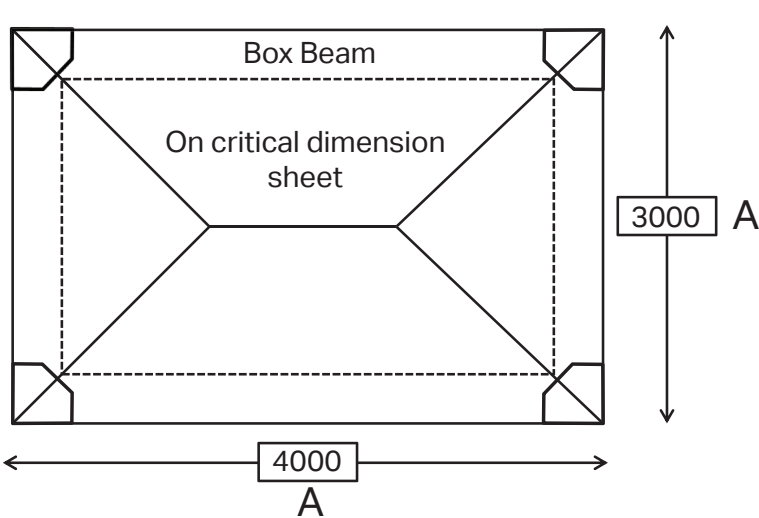

Box beam support shelf placed across 2 adjacent frames. Fit these beam shelves first.

Check dimension A.
Given on critical dimension sheet (example shown below) for box beam support shelf positions.

Unsupported beam shelf. Fit from underside when beams are in position.

Install gallows brackets inline with heads of frames.
If no gallows brackets .
Temporary stud work support frame required under box beam during installation.

Temporary props required to face of box beams during installation (see page 19 main guide).

IMPORTANT

Ensure box beams are fully supported as shown in examples 1 to 4 (see page 2) using temporary timber stud work. Do not remove until box beams are fully assembled, secured and permanent box beam support is fitted. I.e. Gallows brackets.

INSTALLATION - BOX GUTTER - 265MM

265mm box gutter must always be specified on fascia

265mm box gutter must be used when integrated rectangular glass panels strike host wall

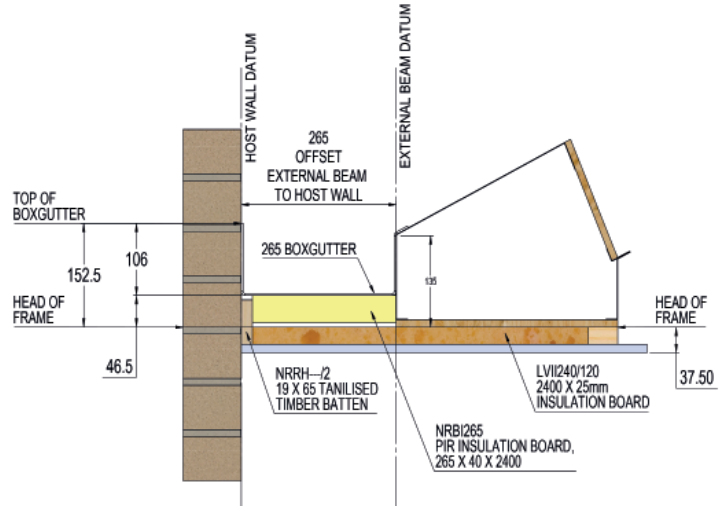
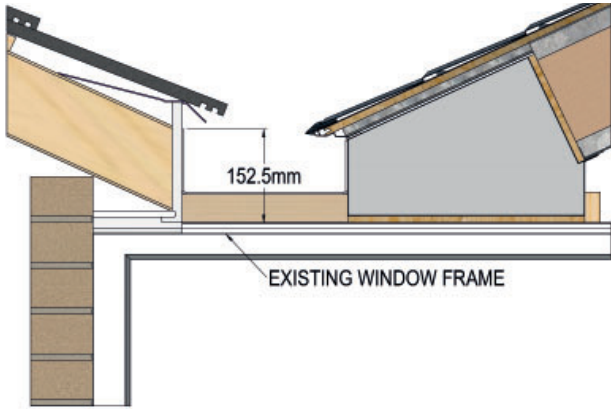

*Insulation / plasterboard drops 37.5mm down face of frame (add on may be necessary)

Example 1

Example 2

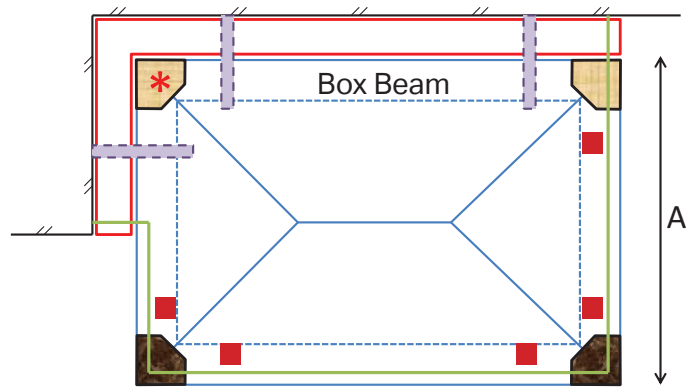
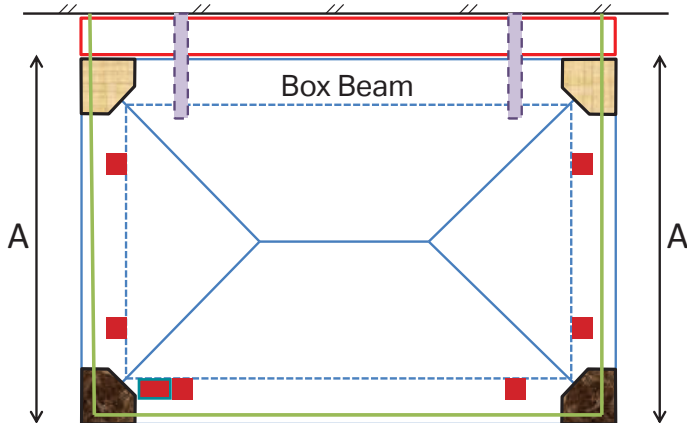

Example 3

Example 4

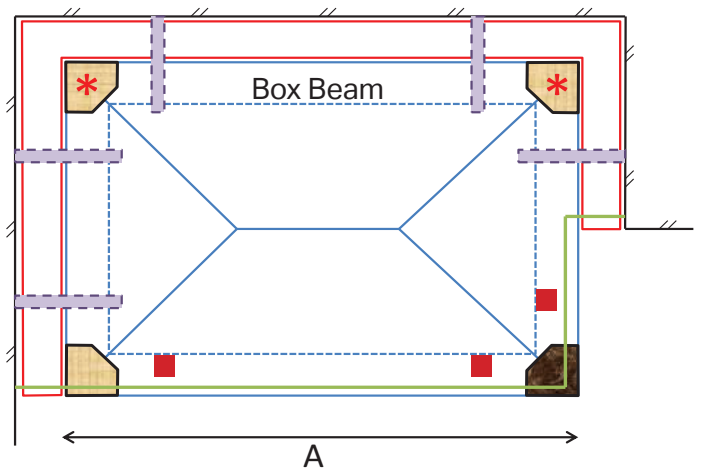
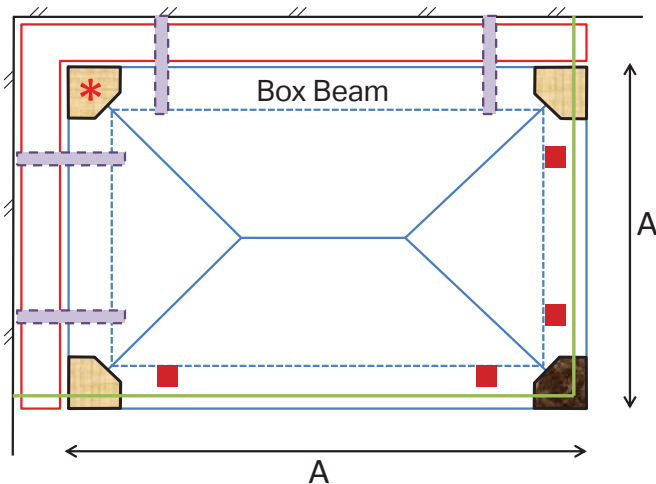

INSTALLATION - BOX GUTTER - 265MM

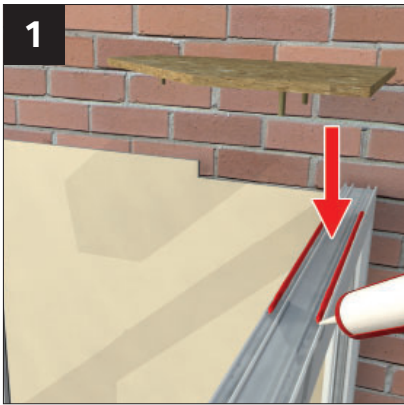

Following example 1 (page 4) apply low modulus neutral clear silicone to head of frame in support shelf position.

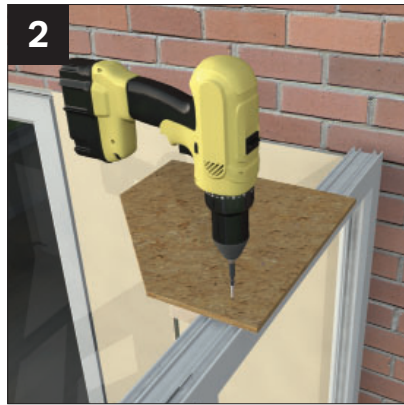

Position support shelf ensuring underside dowels abut internal frame. Secure support shelf with 3x4.8x32, Philips counter sunk self drill screws (NRBA012) provided.



Attach corner cleat (NRBE090) to beam running parallel to host wall before offering into position. Line both edge of cleat with bottom edge of steel using (NRTS100) fixings 12 per cleat.



Position and temporarily fix all box beams following box beam installation sequence and propping instructions detailed on (page 19 main installation guide). Lower boxgutter into position.



Ensure box beams and box gutter are fully supported.

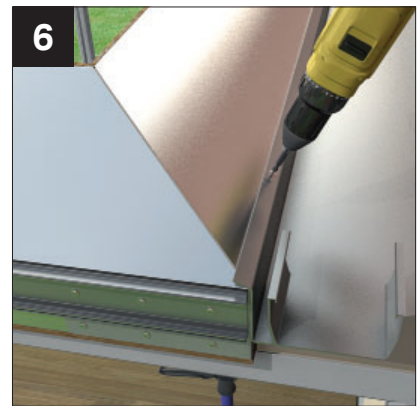

Ensure boxgutter sits tight to box beam and secure with fixings (NRTS100) through lip at 500mm centres. The fastening lip needs to be cut in-line with box beam mitre joint.



Whilst ensuring the boxgutter is level, pack off host wall (where necessary), drill through the back edge at 600mm centres (avoiding mortar joints) and bolt to host wall using masonry anchors suitable to substrate.

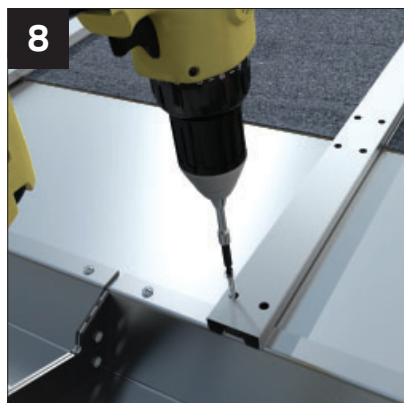

Secure external panel clips.

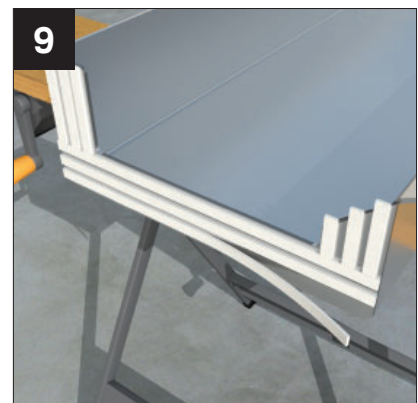

If the box gutter consists of 2 or more sections a joining plate will be welded to adjoining faces. Apply 8mm butyl tape (provided). Space strips as shown to one face only. Ensure vertical strips touch horizontal.

INSTALLATION - BOX GUTTER - 265MM

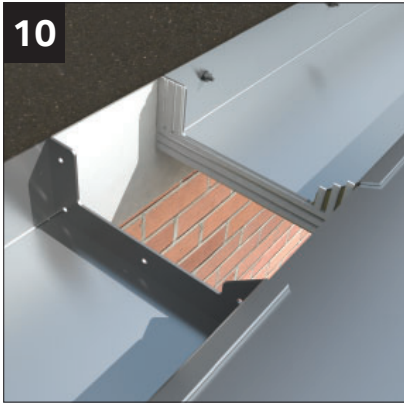

10
Prior to joining peel off protective film on the butyl tape and push tightly together



11
Place the supplied M6 stainless steel bolts (with washer) through predrilled holes. A nylon hammer will help push them through the butyl tape.

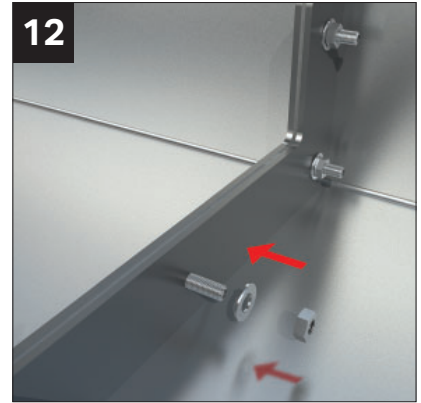

12
Place washer and nut onto bolt and tighten the flanges together, compressing the butyl. A shim in the butyl ensures sufficient sealant remains in the joint to prevent water ingress.



13
Fix the adjoining box gutter through the angled flange into the box beam using (NRTS100) fixings provided at 500mm centres. Pack and fix to host wall as step 7.

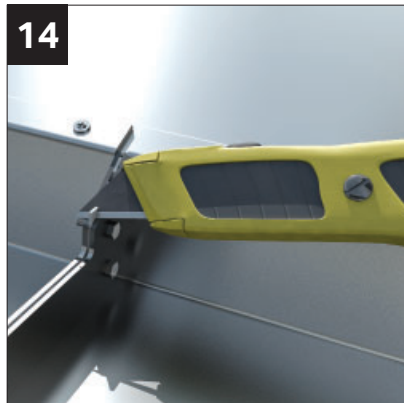

14
Trim any excess butyl tape from the top of the flange.

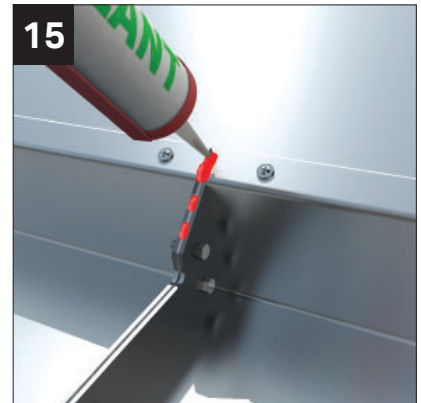

15
Seal with low modulus clear silicone the gap between the 2 flanges of the boxgutter.

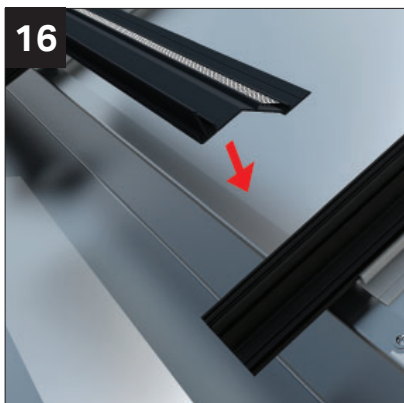

16
If integrated glass units are specified, place the vented glazing trim between the glazing bars. This spaces them correctly

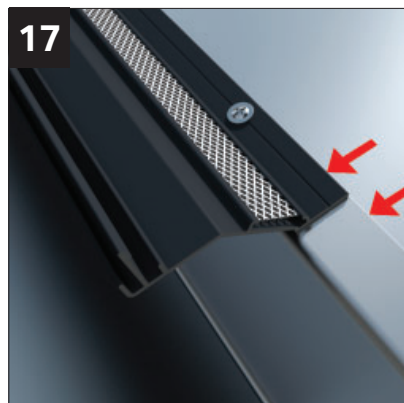

17
Line the rear edge of the glazing support with the top edge of the boxgutter flange. NOTE: Remove any box gutter flange fixings to allow glazing support trim to sit flat fix with (NRTS100) at 200mm centres

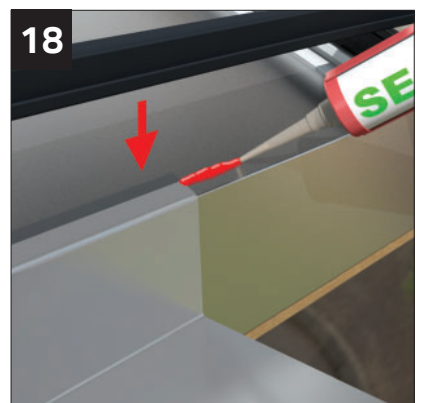

18
Where box gutter ends, silicone along the upper edge of the box beam prior to fixing the the glazing support trim.

INSTALLATION - BOX GUTTER ADAPTORS - 265MM



Straight connection



L connection



T connection



Y connection

INSTALLATION - BOX GUTTER ADAPTORS - 265MM



STRAIGHT CONNECTION
 Specified when the projection of the adjacent wall is less than that of the new building, and where a gutter return is required on the new building only.

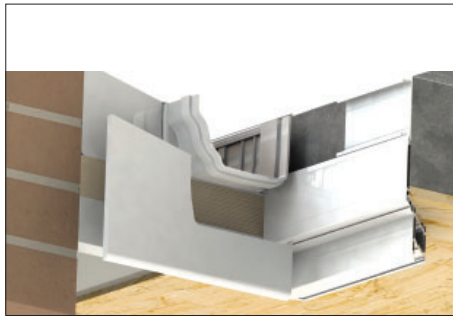

Scribe multiboard to suit.

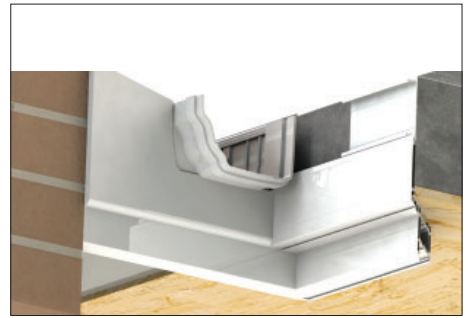

Fix into place.



L CONNECTION
 Specified when the projection of the adjacent wall is equal to or greater than that of the new building, and where a gutter return is required on the new building only.

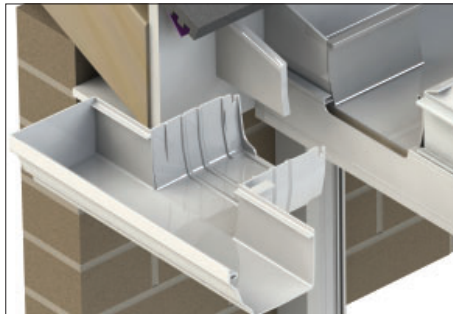

Notch box beam fascia to suit. Scribe multiboard to suit.



Insert box gutter adaptor to stop position.



Y CONNECTION
 Specified when the projection of the adjacent wall is greater than that of the new building, and where a gutter return is required on both the new and existing buildings.



T CONNECTION
 Specified when the projection of the adjacent wall is less than that of the new building, and where a gutter return is required on both the new and existing buildings.



Frame height reduced to accommodate timber packer or PVCu add on. Doing this avoids insulation and plasterboard breaching frame bead line

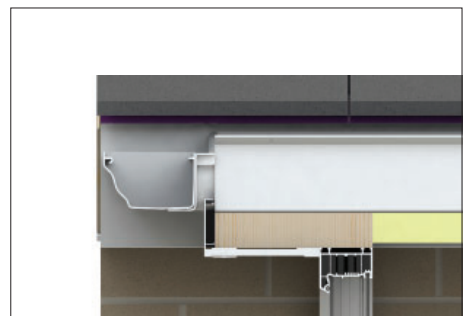

Extended soffit.

STANDARD TAPERED BOX GUTTER

Unlike the 265mm box gutter the tapered box gutter sits directly on top of the boarded roof.

When a tapered boxgutter is used the box beam is always supported by a wall mounted angle bracket that runs along the length of the beam. This instance does not require structural support.

Tapered box gutters are fabricated to suit the roof pitch and includes a 1 in 80 fall. See page 9 and pages 36 to 37 of the complete guide to selling, surveying and specifying Ultrarroof380.

Tapered box gutter shown below is a cut-out (intrusion) where a raised back box gutter would have been used in a conservatory installation. The tapered drains directly to the PVCu gutter (no adaptors).

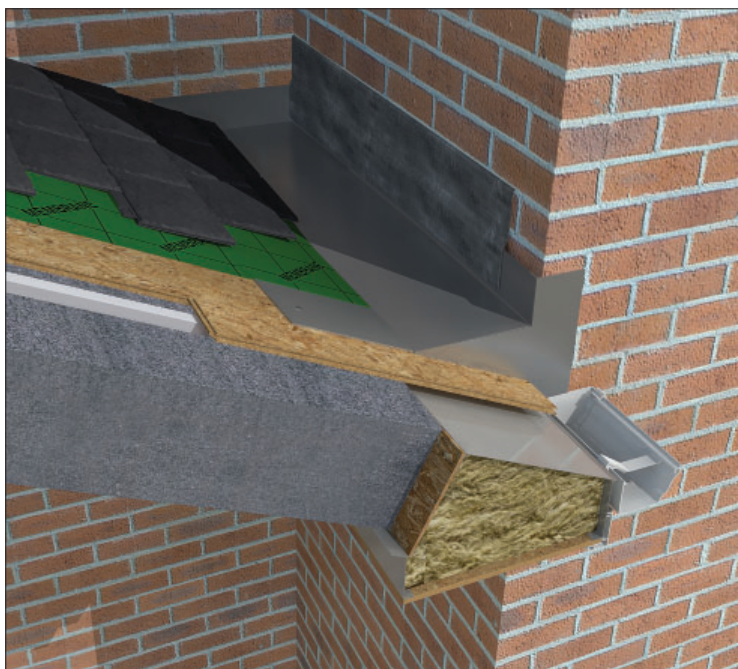

TAPERED BOX GUTTER

Fitting of box beam support shelves.
(Refer to box gutter layout examples on following pages)

USE THE KEY BELOW FOR FITTING SEQUENCE.



Box beam support shelf placed across 2 adjacent frames.
Fit these beam shelves first.



Beam shelf supported by frame and aluminium wall angle bracket. Check dimension A given on critical dimension sheet.



Beam shelf supported across 2 adjacent aluminium wall angle brackets



Temporary props required to face of box beams during installation. (See page 19 of the main installation guide).

TAPERED BOXGUTTER

Example 1

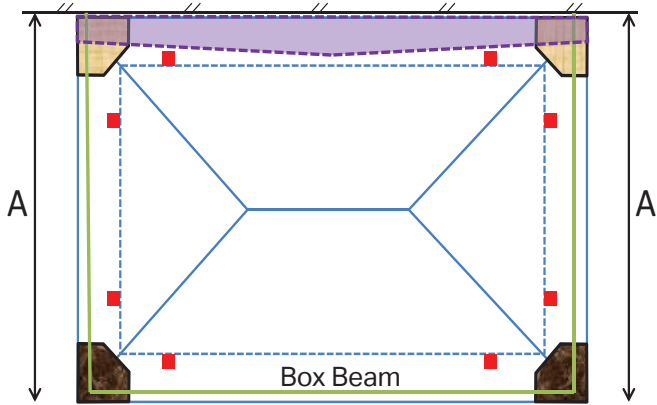

Example 2

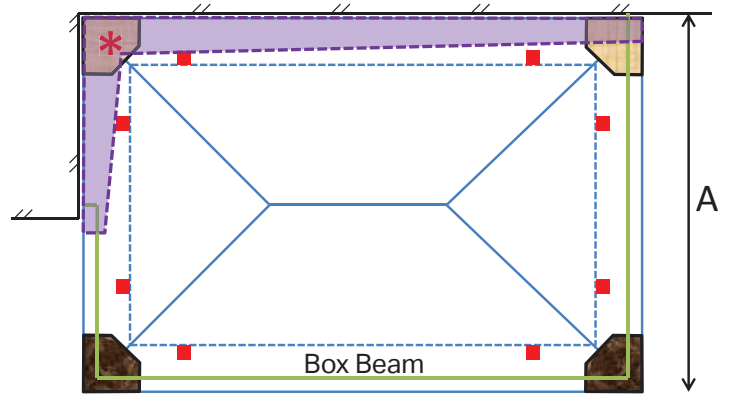

IMPORTANT

Boxgutter specified can be a combination of 265 and Tapered - See page 35 of specification guide for necessary support options.

Example 3

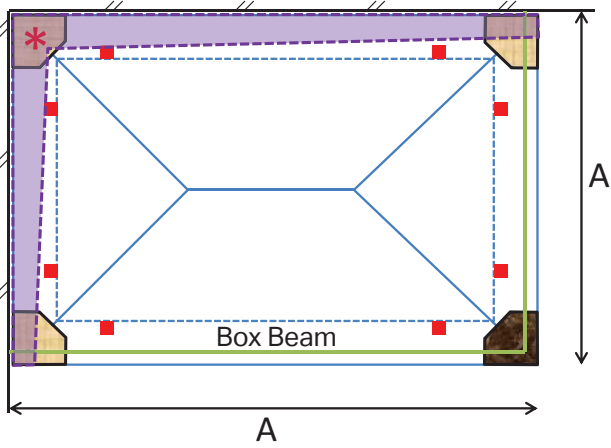

Example 4

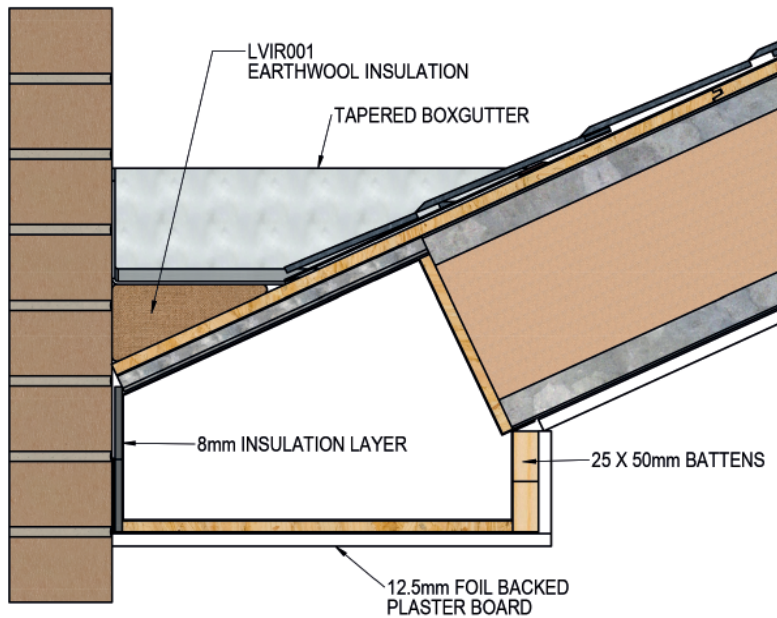
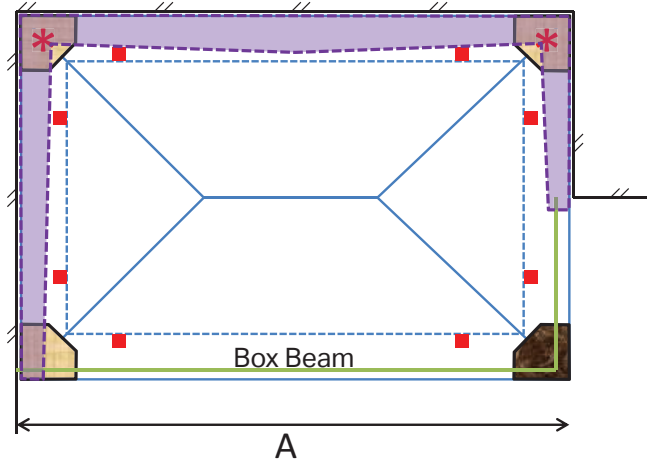

TAPERED BOXGUTTER

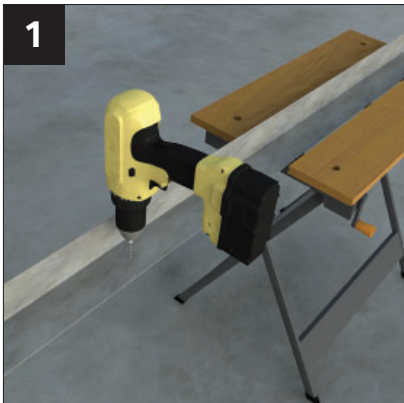

1 Pre-drill the 90° box beam angled wall bracket at 600mm centres (to suit fixing used)



2 Place centrally, aligning top face with head of frames. Bolt to host wall using masonry anchors suitable for substrate (avoiding mortar joints)

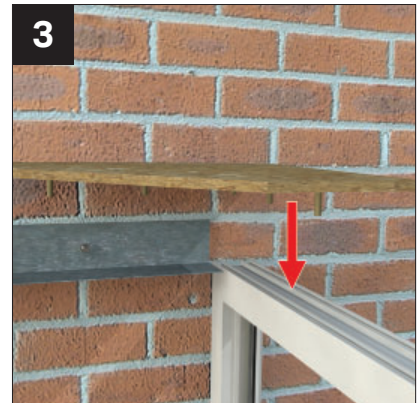

3 Apply low modulus neutral clear silicone to the head of the frames at the corner only. Remove dowels (that would sit on wall bracket) from the beam support shelf



4 Lower into position: Tight back to angled wall bracket. Position dowel guides tight to internal frame

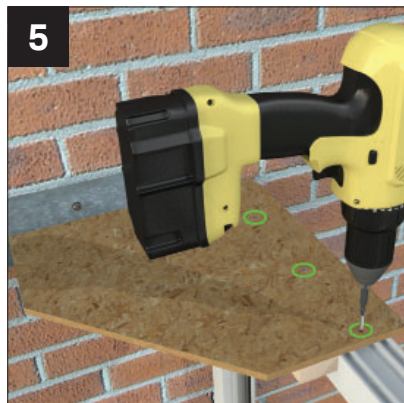

5 Fix support shelf to head of frames using 3x4.8x32mm Philips counter sunk self drill screws (NRBA012) provided.

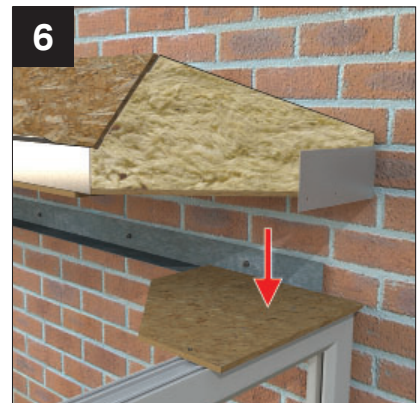

6 Fix the box beam external cleat to the end of the beam using 6 x (NRTS100) screws prior to lifting beam into position. Check beam is positioned centrally, with equal frame overhang. Temporary fix from underside of support shelf.



7 Ensure support shelf locates in the cut-out on the underside of the box beam

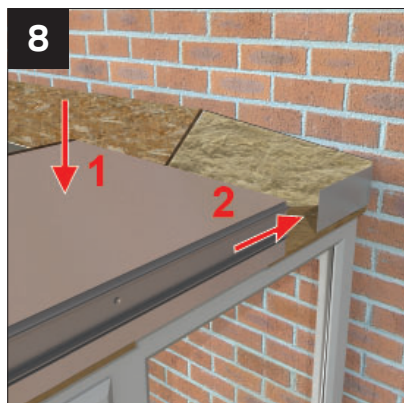

8 Place the opposing box beam on the side frame and slide towards the mating beam



9 Lever the aluminium gutter support channel outwards to enable the external beam cleat to slide behind.

TAPERED BOXGUTTER



Repeat for the other sides and front box beams. Ensure all box beams are level along length and prop to level across their width. Refer to page 19 (main installation guide) for propping. Remove dowels and secure all beams as page 21 (main installation guide).



After levelling and propping, fix the box beam external cleat using 6 x (NRTS100) screws provided. Repeat on all corners.



Attach all top box beams cleats as step 19 on page 20 (main installation guide).



Fix the box beam through the angled support bracket at 500mm centres using 4.2x25mm waferhead self drilling screws (NRTS100) provided.



Pre drill the wall upstand of the tapered box gutter at 600mm centres (to suit appropriate fixings used to secure to host wall).

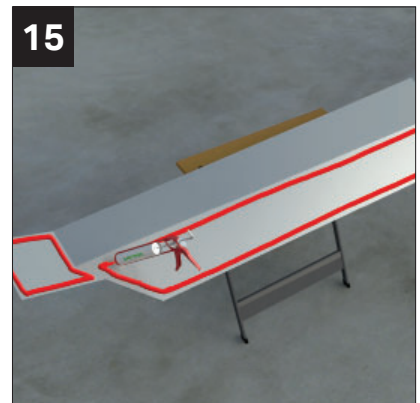

Apply perform adhesive to the underside of the tapered box gutter plate that will rest on the OSB roof deck.

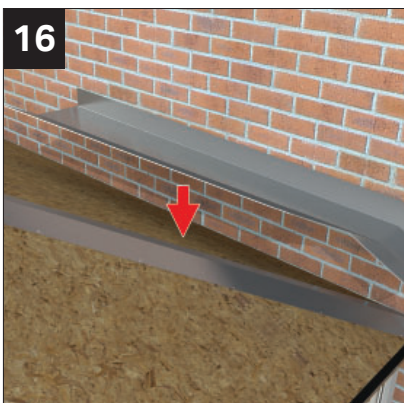

Place tapered box gutter plate onto the OSB roof deck and push down and tight to the host wall. The folded end will lay over the hip and drain towards the gutter.

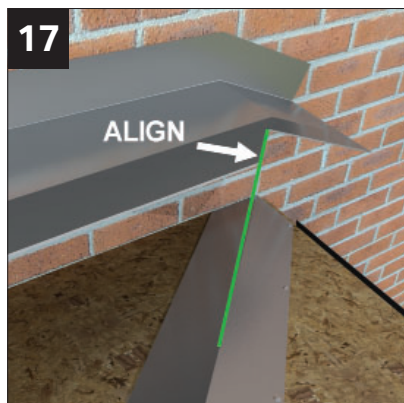

Drill through the pre-drilled holes and secure with the fixings appropriate for the host wall (avoid vertical mortar joints).

TAPERED BOXGUTTER

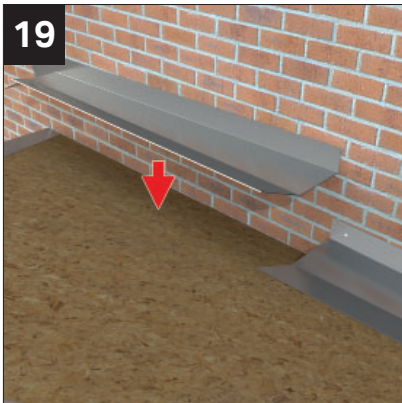

Repeat the process on the opposite side (if applicable). The widest – highest point tapers to the narrowest – lowest point – having a 1 in 80 fall.

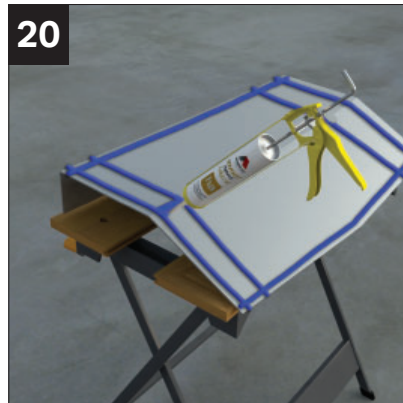

Pre-drill the vertical up stand of the central saddle plate. Then apply perform adhesive to the underside to the pattern shown above.



Apply Perform to the vertical up stand that will be placed against the host wall.

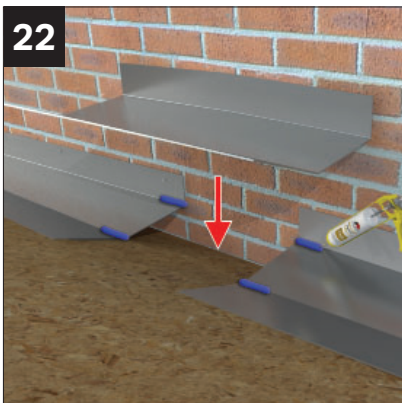

Apply Perform to the top face of the mating plates.

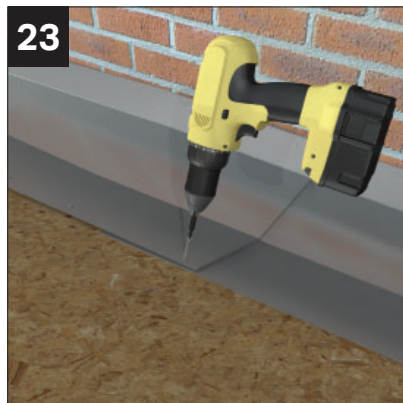

Fix the central saddle plate using 6x4.2x25mm (NRTS100) screws provided.



Apply a strip of (the supplied) high performance butyl tape central to the joint and gently warm to promote adhesion.



Repeat on folded ends, down face of box gutter.

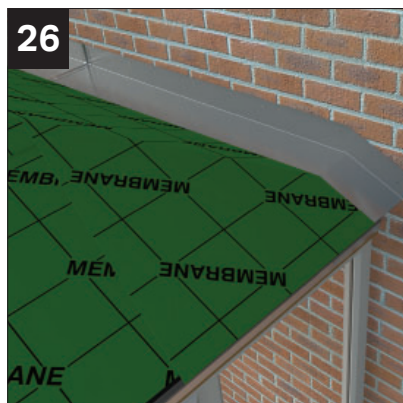

Lay and staple the membrane in-line with the folds in the tapered box gutter.

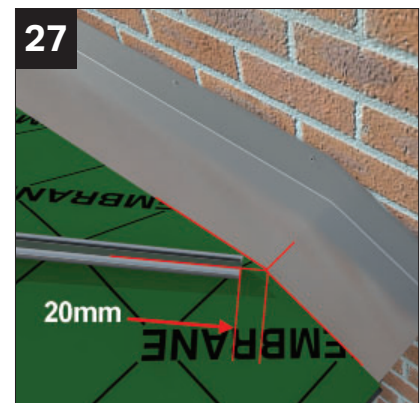

Now temporarily fix the aluminium hip-spines along the centre line of the hip, set approx 20mm up from the folded wing. Mark the outer edges of the hip spine, then remove to aid tiling.

TAPERED BOXGUTTER



From kit supplied, fix Perform tile fixing strips to suit bottom row of tiles using (NRTS100) screws provided (one fixing strip per tile).

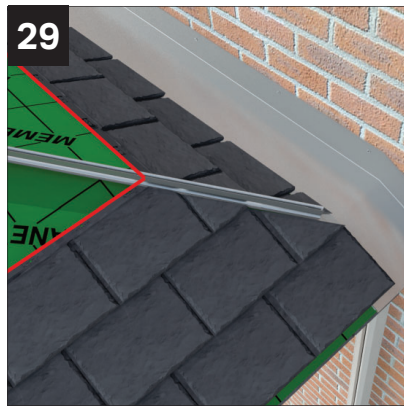

Tile the two side facets using the starter tiles and first row of full tiles to establish where to start the tiles on the box beam facing the hosting wall. The tiles facing the host wall / box gutter are tapered to match the fall of the box gutter plates.

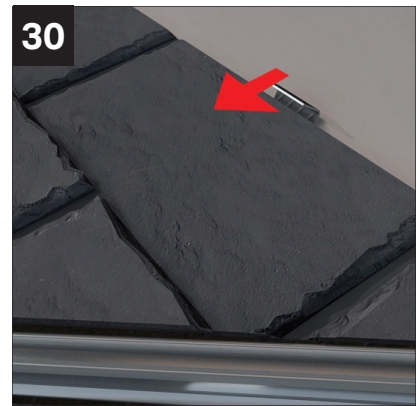

Refer to pages 29 to 33 for tiling method. Bend the Perform tile fixing strips over the lower edges of the tiles to secure.



Permanently fix the hip-spines in position using 4.2x25mm (NRTS100) screws provided at 500mm centres on each side. Finally tap the hip bar top cappings into position.

EXTENDED SOFFIT ONLY ON A SUPER INSULATED COLUMN

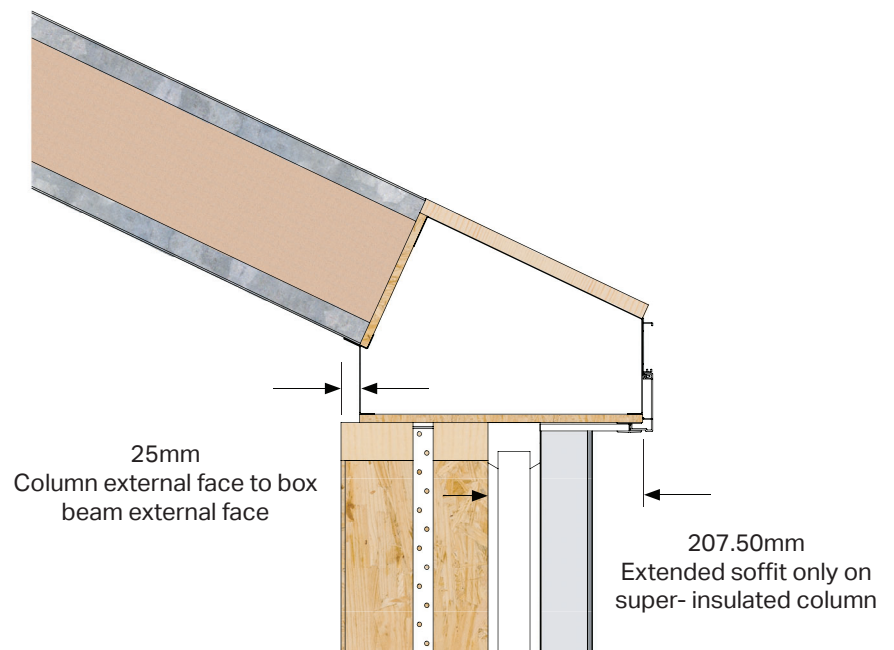

BOX BEAM ON SUPER-INSULATED COLUMN

If your installation contains a super-insulated column, then it is possible to support the box beam on the column providing that the beam is installed with the following details.

Ultraframe

Transforming light and space

www.ultraframetrade.co.uk

Job No.: 3680 01/19 V2 NRBG001

It is Ultraframe's policy to continually seek to improve its products, processes and services, and we reserve the right to change specifications without prior notice. Ultraframe is a trading name of Ultraframe (UK) Limited.