

ClassicTMroof
By Ultraframe



V7 | June 2018

UPVC ROOF VENT INSTALLATION GUIDE

PVC ROOF VENT INSTALLATION GUIDE

CONTENTS

section 1	Pre-installation checks	2
section 2	Roof vent sash	3
section 3	Fitment of mechanical winder	3-4
section 4	Roof vent installation	5
section 5	Optional automatic vent controller	5
	Installation of vent controller	6
section 6	Switch and controller wiring	6
section 7	Installation of rain sensor	7
section 8	Adjustment and testing	7
section 9	Use of controller	7

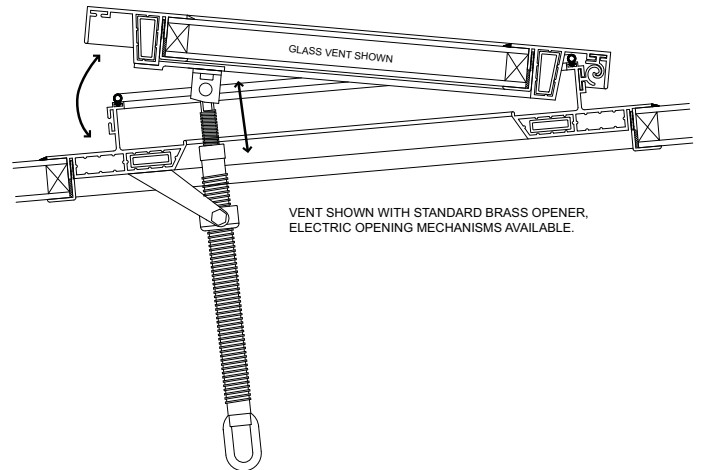

TECHNICAL SUPPORT

Tel: 01200 452918 Email: techsupport@ultraframe.co.uk

Please read in conjunction with the installation guide provided with the roof itself.

PRE INSTALLATION CHECKS

SECTION 1



Unpack the roof vent sash and assemble. If possible, do this in the factory the day before.

ASSEMBLY SHOULD TAKE PLACE BEFORE GOING TO SITE OR FIRST JOB ON SITE

MS Polymer	- Conservaglass - Self cleaning glass
Low modulus neutral cure	- Polycarbonate glazing - Standard sealed units

Always use the correct sealant when assembling / installing the vent.

IMPORTANT: To maximise the cure time for the silicone it is advised that the assembly of the roof vent is carried out either before going to site or first job on site. **Allow a longer cure time in winter.**



ROOF VENT SASH

SECTION 2

IMPORTANT:
The roof vent opening sash must be glazed prior to fitting the vent to the conservatory roof. Leaving the recommended time (dependent on outside air temperature) for the sealant to cure.

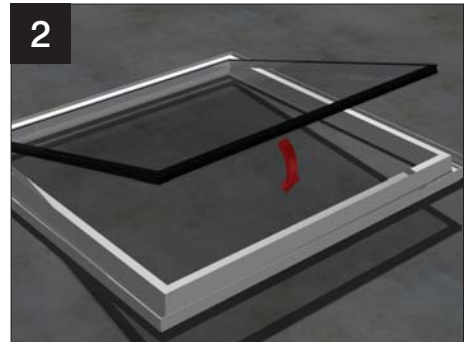
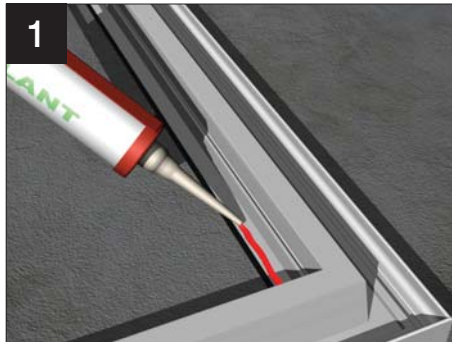

Sealant curing time will vary depending upon the time of year and outside temperature prevailing, this could take up to 8 hours in cold conditions. This is critical when the sash is to be glazed with a sealed unit.

Remove the opening vent sash from the vent mainframe and lay the opening sash upside down on a flat surface. (Protect the surface to prevent damage to the sash). Run a continuous bead of appropriate sealant immediately behind the black co-extruded gasket, taking care to ensure a continuous run around the perimeter of the opening sash.

Remove any handling tape around the perimeter of the unit. When inserting the glazing ensure it is the correct way round and the external face is face down onto the continuous bead of sealant.

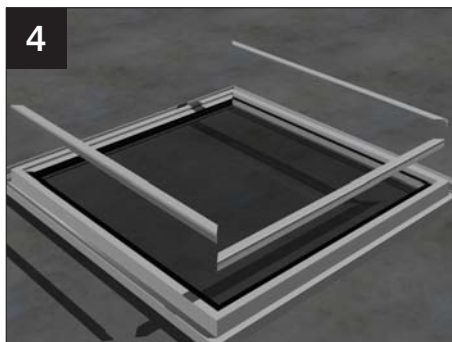

Seal the area around the perimeter of the glazing. On polycarbonate seal all sides other than the bottom breather taped edge. On sealed units seal around the full perimeter of the unit.

Re-fit the 'L' shaped serrated glazing beads to the opening sash. A small block of timber is useful to carefully knock in the beads.

Centrally screw fix the sash bracket into the position shown above using the fixings provided. **Leave the sash to cure before fitting.**

FITMENT OF MECHANICAL WINDER

SECTION 3

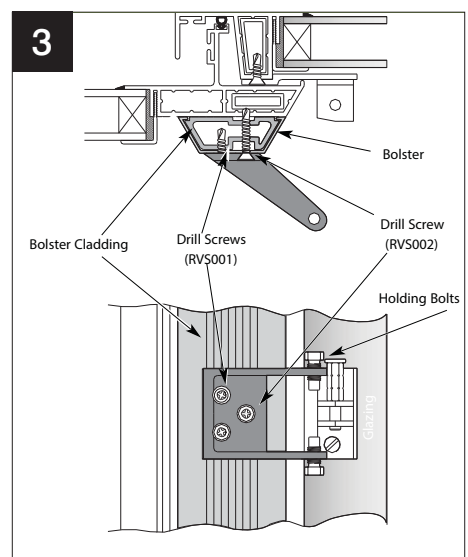
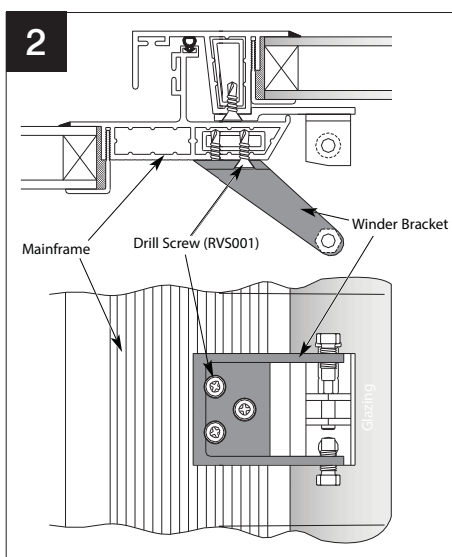
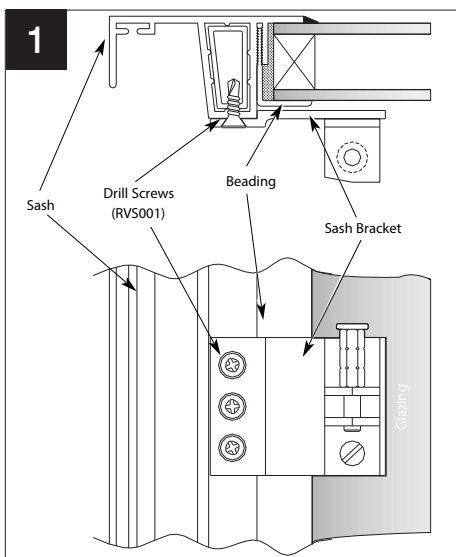

The sash must be removed from the mainframe to fix sash bracket in the relevant position, using the Ø4.8 drill screws (RVS001). Reconnect the sash to the mainframe.

Align the winder bracket and fix to the mainframe, using three Ø4.8 drill screws (RVS001)

When fitting the winder bracket on a bolstered roof vent, two Ø4.8 drill screws (RVS001) and one Ø4.8 drill screw (RVS002) must be used.

4

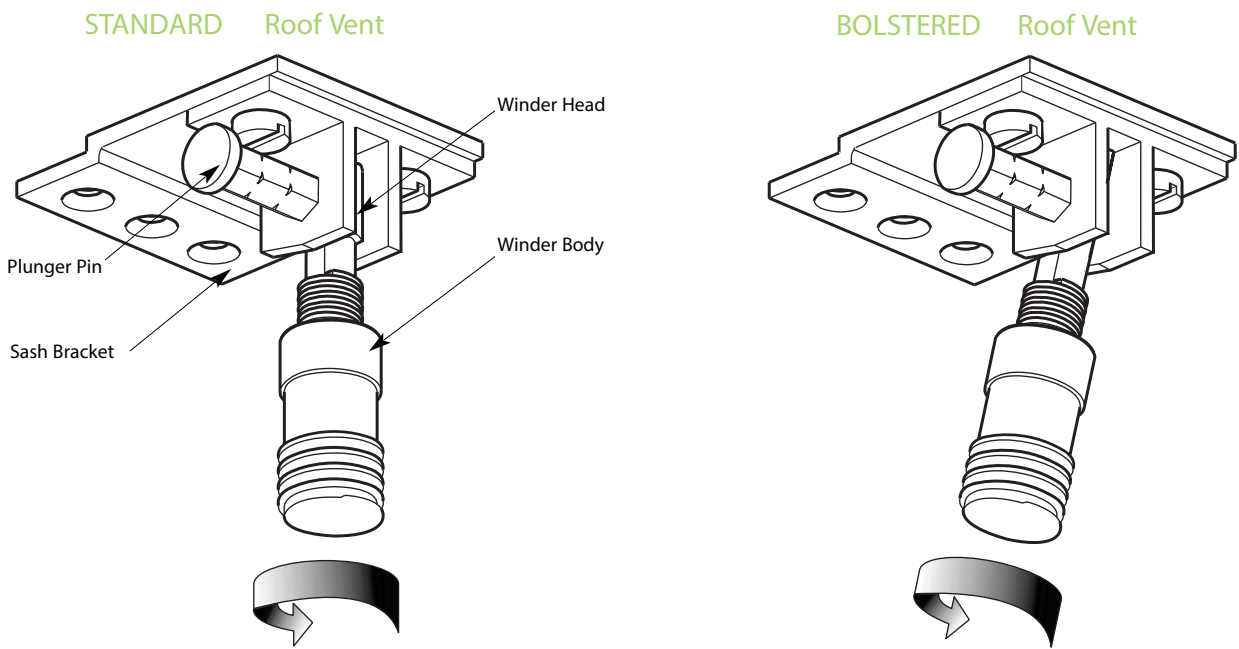

Attach the winder head to the sash bracket, using the plunger pin. Hold the winder at the relevant angle, dependent on whether its standard or bolstered. Turn the winder body clockwise until it locks with the sash bracket.

5

BOLSTERED Roof Vent Shown

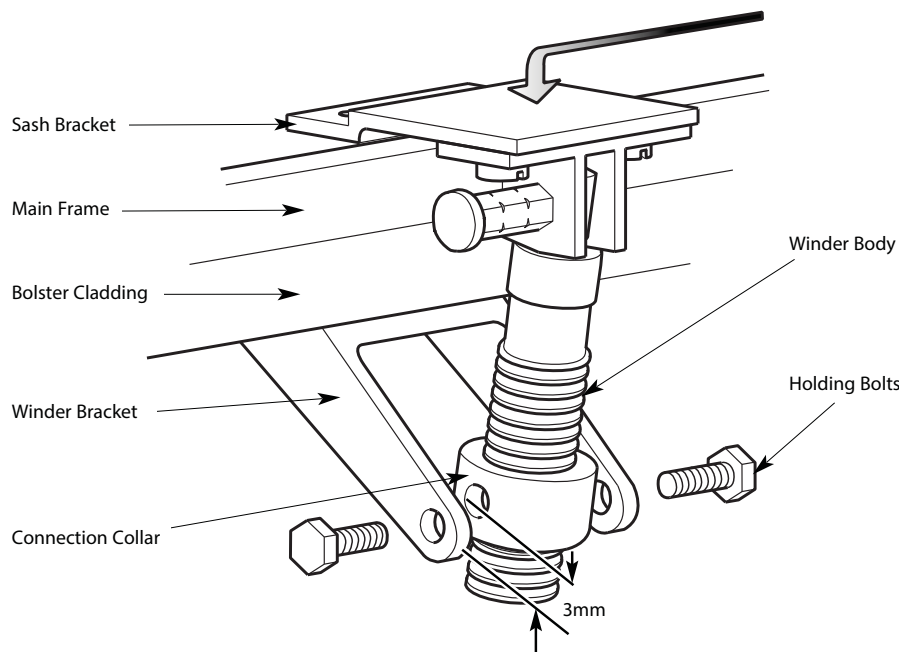

Remove the holding bolts from the winder bracket. Apply downward force to the sash bracket. Turn the connection collar until the holes on the collar are approximately 3mm above the holes in the winder bracket. Holding the connection collar in place, turn the winder body anti-clockwise to loosen the sash bracket. This will enable you to fit the holding bolts without effecting the winder set-up.

NOTE: Downward force is required on the sash bracket, before setting the connection collar. This ensures that when the completed roof vent is in the closed position, it creates a good tight seal on the gaskets.

ROOF VENT INSTALLATION

SECTION 4

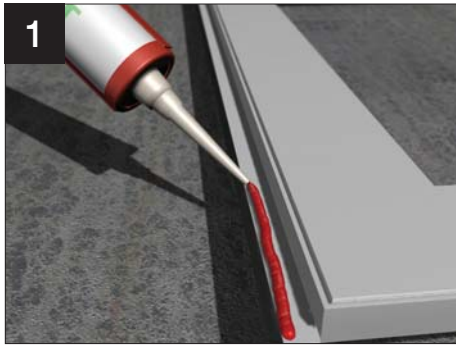

With the opening sash removed, lay the mainframe upside down on a smooth clean surface (protect the surface to prevent damage). Run a continuous bead of sealant (appropriate to the glass type) immediately behind the co-extruded gasket on the upper and lower legs.

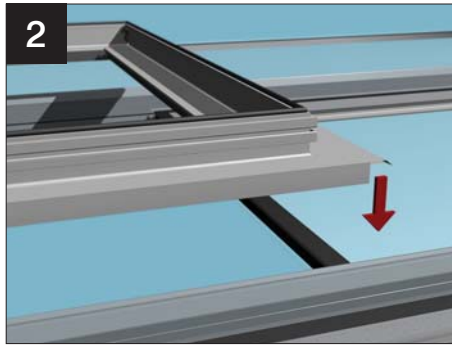

Carefully lower the frame into position on to the upper double glazed unit, making sure that any glazing tape has been removed from the edges of the sealed unit.

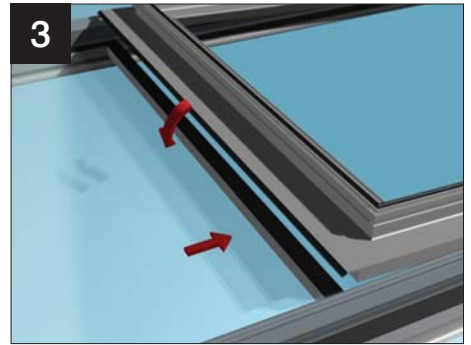

Lift the lower mainframe leg and offer into position the lower double glazed unit. Press down the mainframe firmly into position.

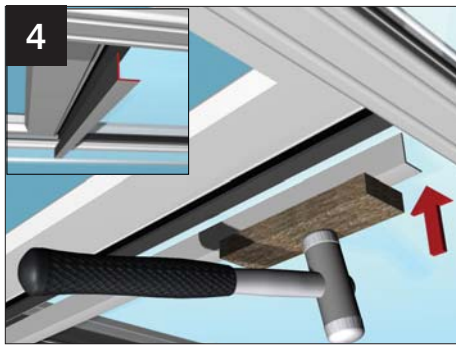

From inside, knock in the 'L' shaped serrated glazing beads to the top and bottom edges of the mainframe. NOTE: We recommend a second person to support the mainframe on the outside whilst carrying out this procedure.

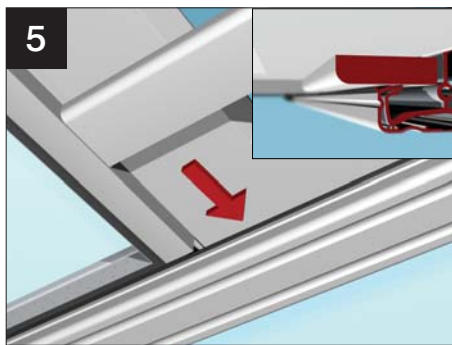

Down each side of the roof vent mainframe an 8mm (or 20mm) thick PVC architrave type packer is provided to suit the glazing thickness. Position as shown above.

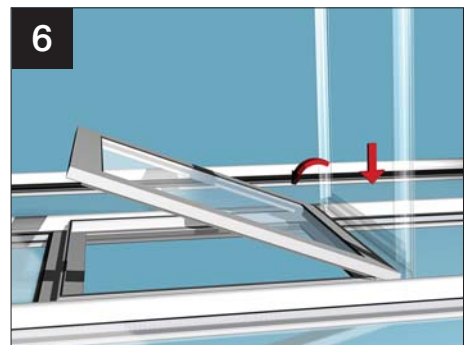

When the sealant on the mainframe has cured, re-fit the outer sash by holding vertically and re-engage on to the 'S' shaped hinge, before lowering into position.

OPTIONAL AUTOMATIC VENT CONTROLLER

SECTION 5

NOTE: CABLE NOT SUPPLIED BY ULTRAFRAME

The Automatic Vent Controller is an integrated electronic thermostat and controller with rain sensor, for automatic and manual operation of motorised roof vents. The vents open automatically at high temperatures and close again when the temperature drops or rain is detected. Up to 6 Ultraframe actuators can be controlled by type AVM 003.



TECHNICAL SPECIFICATION

Mains Supply: 230V 5A 50Hz
Output current to actuators: 5.2A max at 20% duty cycle
Opening impulse: Variable, 3 to 9 sec approx.
Closing impulse: 11 sec approx
Differential temp of thermostat: 2°C
Mounting angle of rain sensor: 15° to 45°
Cable for rain sensor: 0.5mm² 2 core round flexible cable. Ø5 to 7mm

Working voltage of rain sensor: 1V to 6V wet - 7.5V to 10V dry (a.c.)

Equivalent resistance of rain sensor: Less than 80k ohms wet. Greater than 300k ohms dry

Finish: White only

Dimensions of controller: 148 x 88 x 52 excluding thermostat setting knob

Dimensions of rain sensor: 75 x 51 x 28 excluding cable gland

Weight of combined units in packing carton: 450g

THIS UNIT MUST BE INSTALLED BY A QUALIFIED ELECTRICIAN TO THE 17th EDITION BS7671 REQUIREMENTS FOR ELECTRICAL INSTALLATIONS

1. Remove the front panel by loosening the retaining screws.
2. Screw the back box to the surface of a masonry wall in the conservatory, at the usual height of a wall switch.
3. Choose appropriate knock out for cable entry and smooth edges to prevent damage to cable insulation.
4. In any situation where the mains cable is not plastered into the wall, the cable must be adequately secured as close as possible to the control box to prevent undue stress on the cable.
5. Connect the cables in accordance with the wiring diagram, bringing sheath as close as possible to the terminal blocks, to prevent contact of the inner insulation with other parts of the p.c.b. Note that a junction box will be required in the ridge, to bring all the actuator cables together. Run a single four-core cable from here to the control box. Note that a fused isolator must be installed, providing a contact separation of at least 3mm in all poles.
6. Replace the front panel.

THIS UNIT TO BE INSTALLED USING BASEC OR HAR APPROVED CABLE, AND MUST BE SUITABLY EARTHED
NOTE: CABLE NOT SUPPLIED BY ULTRAFRAME

SWITCH AND CONTROLLER WIRING

SECTION 6

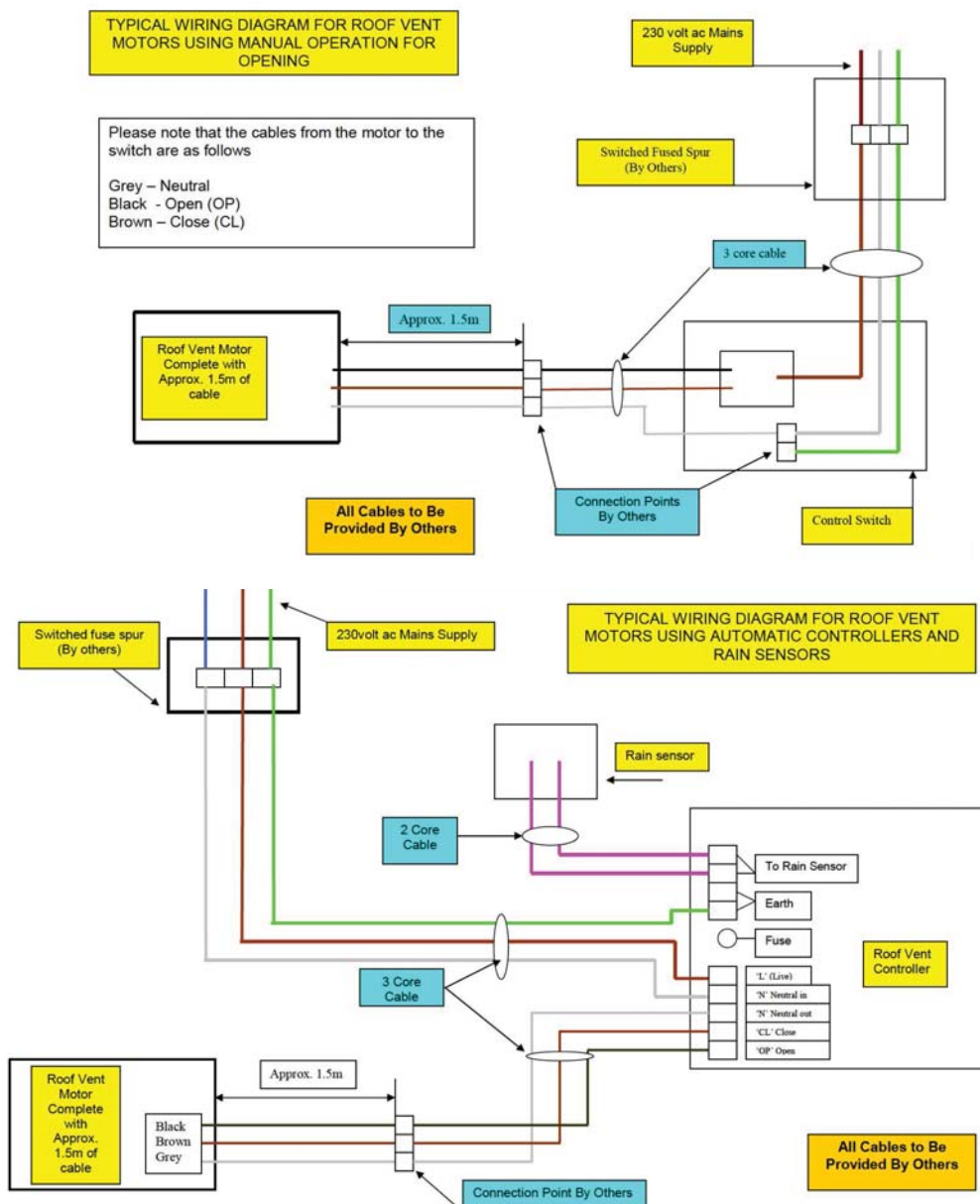

INSTALLATION OF RAIN SENSOR

SECTION 7

1. Pass the cable through the cable gland, strip the cable ends and crimp on the terminals supplied.

2. Push the terminals on to the blades. Do not over tighten the nuts and screws, or the conductive pattern may be damaged by indentation.

NOTE: Round 3A mains cable must be used to ensure that the cable gland grips the cable and forms a waterproof seal. (This cable carries only 9V a.c. however).

3. Fit the bottom cover without sealing the joint

4. Attach the unit with the self-adhesive pad provided to a convenient exposed part of the roof, with the black sensing pattern uppermost. The cable can point towards the ridge, gutter, or to either side. The unit must slope at a gradient of at least 15° to enable excess water to run off. Packing may be required on a lean-to roof to ensure this. Avoid shelter from overhanging eaves, especially if the conservatory is on the sheltered side of a taller building (house etc). In the UK the prevailing wind and most rainfall comes from the South-West. This is therefore the preferred side of the roof for the rain sensor, but check local conditions, especially on the East Coast or on Mainland Europe.

15° TO 45° PITCH

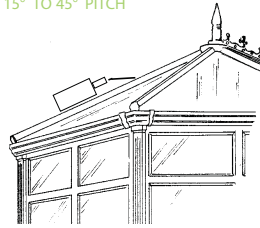

PACKING WHEN PITCH IS LESS THAN 15°

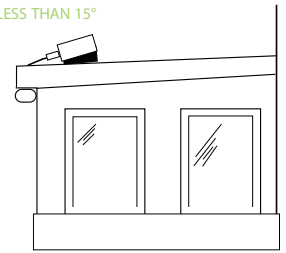

Rain Sensor Mounting Position

ADJUSTMENT AND TESTING

SECTION 8

OPENING ADJUSTMENT

Within the opening distance selected at the actuator, the opening distance when opening automatically can be adjusted in the range 100-300mm by turning the control as required. See drawing of controller. **This is not a “customer control”**. It should be pre-set by the installing electrician if the customer requests it. **Note that the opening distance is reduced by turning clockwise.**

TESTING

1. When the installation is complete, insert the supply fuse and switch the isolator on. Note that the vents are likely to open or close on power-up.

2. First check for correct operation of the vents by use of the tactile open/close switches.

IT IS VITAL THAT WHEN THE VENTS ARE CLOSED FULLY, THEY ARE NOT TOO TIGHTLY CLOSED.

Set these as per instruction sheet CIL144.

3. In warmer weather, automatic operation can be checked by turning the thermostat up and down. Note that the vent should **OPEN** when turned to a low temperature and **CLOSE** when turned to a high temperature.

In cold weather i.e: below 10°C in the conservatory, the thermostat element can be warmed up by using a hair dryer on a **LOW** heat setting. This should cause the vents to open. Turn the thermostat up to check that they close.

4. To test the rain sensor, the vents must first be opened and clean water sprayed onto the rain sensor. The vents should close within a few seconds.

NOTE: a wet rain sensor will prevent automatic opening. If testing in actual rain, the surface of the sensor can be dried with clean kitchen tissue. Take care that the sensing surface is not scratched. It must also be kept free of grease and sealing compound.

USE OF CONTROLLER

SECTION 9

THERMOSTAT ADJUSTMENT

The adjustment range of the thermostat is 10° to 30°C. Set the control knob to the temperature at which you want automatic operation of the vents. The vents will open whenever the temperature rises above your setting and re-close when it falls below this setting.

RAIN SENSOR

A rain sensor mounted on the roof will prevent automatic opening of the vents, and will cause them to re-close if it rains when they are already open.

MANUAL CONTROL

The tactile switches can be operated at any time to temporarily override the automatic actions of the controller. With these switches you can set the vents to any desired position. Press the “open” switch to open vent and press the “close” switch to close vent. Note that automatic operation will resume, commensurate with climatic conditions and the thermostat setting.

NOTE

1. Following a period of rain, the rain sensor will take some time to dry. Whilst still wet, it will hold the vents closed, and immediately re-close them if opened by the tactile switch.

2. If you wish to leave the vents in any fixed position, first use the open/close tactile switch, then switch off the electric supply at the isolator.

www.ultraframetrade.co.uk

Ultraframe[®]
Transforming light and space

Job No.: 2393 AVTD002INST qty5,000 APS 6/2018 v7

It is Ultraframe's policy to continually seek to improve its products, processes and services, and we reserve the right to change specifications without prior notice. Ultraframe is a trading name of Ultraframe (UK) Limited.